

8 Mbit / 16 Mbit (x16) Multi-Purpose Flash

SST39LF800 / SST39LF160 / SST39VF800 / SST39VF160



Data Sheet

FEATURES:

- **Organized as 512K x16 / 1M x16**
- **Single Voltage Read and Write Operations**
 - 3.0-3.6V for SST39LF800/160
 - 2.7-3.6V for SST39VF800/160
- **Superior Reliability**
 - Endurance: 100,000 Cycles (typical)
 - Greater than 100 years Data Retention
- **Low Power Consumption:**
 - Active Current: 15 mA (typical)
 - Standby Current: 4 μ A (typical)
 - Auto Low Power Mode: 4 μ A (typical)
- **Sector-Erase Capability**
 - Uniform 2 KWord sectors
- **Block-Erase Capability**
 - Uniform 32 KWord blocks
- **Fast Read Access Time:**
 - 55 ns for SST39LF800/160
 - 70 and 90 ns for SST39VF800/160
- **Latched Address and Data**
- **Fast Erase and Word-Program:**
 - Sector-Erase Time: 18 ms (typical)
 - Block-Erase Time: 18 ms (typical)
 - Chip-Erase Time: 70 ms (typical)
 - Word-Program Time: 14 μ s (typical)
 - Chip Rewrite Time:
 - 8 seconds (typical) for SST39LF/VF800
 - 15 seconds (typical) for SST39LF/VF160
- **Automatic Write Timing**
 - Internal V_{PP} Generation
- **End-of-Write Detection**
 - Toggle Bit
 - Data# Polling
- **CMOS I/O Compatibility**
- **JEDEC Standard**
 - Flash EEPROM Pinouts and command sets
- **Packages Available**
 - 44-Pin SOIC (500mil)
 - 48-Pin TSOP (12mm x 20mm)
 - 48-Ball TFBGA (8mm x 10mm)

PRODUCT DESCRIPTION

The SST39LF800/160 and SST39VF800/160 devices are 512K x16 / 1M x16 CMOS Multi-Purpose Flash (MPF) manufactured with SST's proprietary, high performance CMOS SuperFlash technology. The split-gate cell design and thick oxide tunneling injector attain better reliability and manufacturability compared with alternate approaches. The SST39LF800/160 write (Program or Erase) with a 3.0-3.6V power supply. The SST39VF800/160 write (Program or Erase) with a 2.7-3.6V power supply. These devices conform to JEDEC standard pinouts for x16 memories.

Featuring high performance Word-Program, the SST39LF800/160 and SST39VF800/160 devices provide a typical Word-Program time of 14 μ sec. These devices use Toggle Bit or Data# Polling to indicate the completion of Program operation. To protect against inadvertent write, they have on-chip hardware and Software Data Protection schemes. Designed, manufactured, and tested for a wide spectrum of applications, these devices are offered with a guaranteed endurance of 10,000 cycles. Data retention is rated at greater than 100 years.

The SST39LF800/160 and SST39VF800/160 devices are suited for applications that require convenient and economical updating of program, configuration, or data memory. For all system applications, they significantly improve performance and reliability, while lowering

power consumption. They inherently use less energy during Erase and Program than alternative flash technologies. The total energy consumed is a function of the applied voltage, current, and time of application. Since for any given voltage range, the SuperFlash technology uses less current to program and has a shorter erase time, the total energy consumed during any Erase or Program operation is less than alternative flash technologies. These devices also improve flexibility while lowering the cost for program, data, and configuration storage applications.

The SuperFlash technology provides fixed Erase and Program times, independent of the number of Erase/Program cycles that have occurred. Therefore the system software or hardware does not have to be modified or de-rated as is necessary with alternative flash technologies, whose Erase and Program times increase with accumulated Erase/Program cycles.

To meet high density, surface mount requirements, the SST39LF800/160 and SST39VF800/160 are offered in 44-pin SOIC, 48-pin TSOP and 48-pin TFBGA packages. See Figures 1, 2 and 3 for pinouts.

Device Operation

Commands are used to initiate the memory operation functions of the device. Commands are written to the device using standard microprocessor write sequences. A command is written by asserting WE# low while



8 Mbit / 16 Mbit Multi-Purpose Flash SST39LF800 / SST39LF160 / SST39VF800 / SST39VF160

Data Sheet

keeping CE# low. The address bus is latched on the falling edge of WE# or CE#, whichever occurs last. The data bus is latched on the rising edge of WE# or CE#, whichever occurs first.

The SST39LF800/160 and SST39VF800/160 also have the **Auto Low Power** mode which puts the device in a near standby mode after data has been accessed with a valid Read operation. This reduces the I_{DD} active read current from typically 15 mA to typically 4 μ A. The Auto Low Power mode reduces the typical I_{DD} active read current to the range of 1 mA/MHz of read cycle time. The device exits the Auto Low Power mode with any address transition or control signal transition used to initiate another Read cycle, with no access time penalty.

Read

The Read operation of the SST39LF800/160 and SST39VF800/160 is controlled by CE# and OE#, both have to be low for the system to obtain data from the outputs. CE# is used for device selection. When CE# is high, the chip is deselected and only standby power is consumed. OE# is the output control and is used to gate data from the output pins. The data bus is in high impedance state when either CE# or OE# is high. Refer to the Read cycle timing diagram for further details (Figure 4).

Word-Program Operation

The SST39LF800/160 and SST39VF800/160 are programmed on a word-by-word basis. The Program operation consists of three steps. The first step is the three-byte load sequence for Software Data Protection. The second step is to load word address and word data. During the Word-Program operation, the addresses are latched on the falling edge of either CE# or WE#, whichever occurs last. The data is latched on the rising edge of either CE# or WE#, whichever occurs first. The third step is the internal Program operation which is initiated after the rising edge of the fourth WE# or CE#, whichever occurs first. The Program operation, once initiated, will be completed within 20 μ s. See Figures 5 and 6 for WE# and CE# controlled Program operation timing diagrams and Figure 17 for flowcharts. During the Program operation, the only valid reads are Data# Polling and Toggle Bit. During the internal Program operation, the host is free to perform additional tasks. Any commands issued during the internal Program operation are ignored.

Sector/Block-Erase Operation

The Sector- (or Block-) Erase operation allows the system to erase the device on a sector-by-sector (or block-by-block) basis. The SST39LF800/160 and SST39VF800/160 offer both Sector-Erase and Block-Erase mode. The sector architecture is based on uniform sector size of 2

KWord. The Block-Erase mode is based on uniform block size of 32 KWord. The Sector-Erase operation is initiated by executing a six-byte command sequence with Sector-Erase command (30H) and sector address (SA) in the last bus cycle. The Block-Erase operation is initiated by executing a six-byte command sequence with Block-Erase command (50H) and block address (BA) in the last bus cycle. The sector or block address is latched on the falling edge of the sixth WE# pulse, while the command (30H or 50H) is latched on the rising edge of the sixth WE# pulse. The internal Erase operation begins after the sixth WE# pulse. The End-of-Erase operation can be determined using either Data# Polling or Toggle Bit methods. See Figures 10 and 11 for timing waveforms. Any commands issued during the Sector- or Block-Erase operation are ignored.

Chip-Erase Operation

The SST39LF800/160 and SST39VF800/160 provide a Chip-Erase operation, which allows the user to erase the entire memory array to the "1" state. This is useful when the entire device must be quickly erased.

The Chip-Erase operation is initiated by executing a six-byte command sequence with Chip-Erase command (10H) at address 5555H in the last byte sequence. The Erase operation begins with the rising edge of the sixth WE# or CE#, whichever occurs first. During the Erase operation, the only valid read is Toggle Bit or Data# Polling. See Table 4 for the command sequence, Figure 9 for timing diagram, and Figure 20 for the flowchart. Any commands issued during the Chip-Erase operation are ignored.

Write Operation Status Detection

The SST39LF800/160 and SST39VF800/160 provide two software means to detect the completion of a Write (Program or Erase) cycle, in order to optimize the system write cycle time. The software detection includes two status bits: Data# Polling (DQ₇) and Toggle Bit (DQ₆). The End-of-Write detection mode is enabled after the rising edge of WE#, which initiates the internal Program or Erase operation.

The actual completion of the nonvolatile write is asynchronous with the system; therefore, either a Data# Polling or Toggle Bit read may be simultaneous with the completion of the write cycle. If this occurs, the system may possibly get an erroneous result, i.e., valid data may appear to conflict with either DQ₇ or DQ₆. In order to prevent spurious rejection, if an erroneous result occurs, the software routine should include a loop to read the accessed location an additional two (2) times. If both reads are valid, then the device has completed the Write cycle, otherwise the rejection is valid.



8 Mbit / 16 Mbit Multi-Purpose Flash

SST39LF800 / SST39LF160 / SST39VF800 / SST39VF160

Data Sheet

Data# Polling (DQ₇)

When the SST39LF800/160 and SST39VF800/160 are in the internal Program operation, any attempt to read DQ₇ will produce the complement of the true data. Once the Program operation is completed, DQ₇ will produce true data. The device is then ready for the next operation. During internal Erase operation, any attempt to read DQ₇ will produce a '0'. Once the internal Erase operation is completed, DQ₇ will produce a '1'. The Data# Polling is valid after the rising edge of fourth WE# (or CE#) pulse for Program operation. For Sector-, Block- or Chip-Erase, the Data# Polling is valid after the rising edge of sixth WE# (or CE#) pulse. See Figure 7 for Data# Polling timing diagram and Figure 18 for a flowchart.

Toggle Bit (DQ₆)

During the internal Program or Erase operation, any consecutive attempts to read DQ₆ will produce alternating 1's and 0's, i.e., toggling between 1 and 0. When the internal Program or Erase operation is completed, the DQ₆ bit will stop toggling. The device is then ready for the next operation. The Toggle Bit is valid after the rising edge of fourth WE# (or CE#) pulse for Program operation. For Sector-, Block- or Chip-Erase, the Toggle Bit is valid after the rising edge of sixth WE# (or CE#) pulse. See Figure 8 for Toggle Bit timing diagram and Figure 18 for a flowchart.

Data Protection

The SST39LF800/160 and SST39VF800/160 provide both hardware and software features to protect nonvolatile data from inadvertent writes.

Hardware Data Protection

Noise/Glitch Protection: A WE# or CE# pulse of less than 5 ns will not initiate a write cycle.

V_{DD} Power Up/Down Detection: The Write operation is inhibited when V_{DD} is less than 1.5V.

Write Inhibit Mode: Forcing OE# low, CE# high, or WE# high will inhibit the Write operation. This prevents inadvertent writes during power-up or power-down.

Software Data Protection (SDP)

The SST39LF800/160 and SST39VF800/160 provide the JEDEC approved Software Data Protection scheme for all data alteration operations, i.e., Program and Erase. Any Program operation requires the inclusion of the three-byte sequence. The three-byte load sequence is used to initiate the Program operation, providing optimal protection from inadvertent Write operations, e.g., during the system power-up or power-down. Any Erase operation requires the inclusion of six-byte sequence. These devices are shipped with the Software Data Protection permanently enabled. See Table 4 for the specific software command

codes. During SDP command sequence, invalid commands will abort the device to read mode within T_{RC}. The contents of DQ₁₅-DQ₈ are "Don't Care" during any SDP command sequence.

Common Flash Memory Interface (CFI)

The SST39LF800/160 and SST39VF800/160 also contain the CFI information to describe the characteristics of the device. In order to enter the CFI Query mode, the system must write three-byte sequence, same as product ID entry command with 98H (CFI Query command) to address 5555H in the last byte sequence. Once the device enters the CFI Query mode, the system can read CFI data at the addresses given in tables 5 through 7. The system must write the CFI Exit command to return to Read mode from the CFI Query mode.

Product Identification

The Product Identification mode identifies the devices as the SST39LF/VF800, SST39LF/VF160 and manufacturer as SST. This mode may be accessed by hardware or software operations. The hardware operation is typically used by a programmer to identify the correct algorithm for the SST39LF800/160 and SST39VF800/160. Users may wish to use the Software Product Identification operation to identify the part (i.e., using the device code) when using multiple manufacturers in the same socket. For details, see Table 3 for hardware operation or Table 4 for software operation, Figure 12 for the Software ID Entry and Read timing diagram and Figure 19 for the Software ID Entry command sequence flowchart.

TABLE 1: PRODUCT IDENTIFICATION TABLE

	Address	Data
Manufacturer's Code	0000H	00BFH
Device Code SST39LF/VF800	0001H	2781H
Device Code SST39LF/VF160	0001H	2782H

399 PGM T1.0

Product Identification Mode Exit/CFI Mode Exit

In order to return to the standard Read mode, the Software Product Identification mode must be exited. Exit is accomplished by issuing the Software ID Exit command sequence, which returns the device to the Read operation. This command may also be used to reset the device to the Read mode after any inadvertent transient condition that apparently causes the device to behave abnormally, e.g., not read correctly. Please note that the Software ID Exit/CFI Exit command is ignored during an internal Program or Erase operation. See Table 4 for software command codes, Figure 14 for timing waveform and Figure 19 for a flowchart.



8 Mbit / 16 Mbit Multi-Purpose Flash SST39LF800 / SST39LF160 / SST39VF800 / SST39VF160

Data Sheet

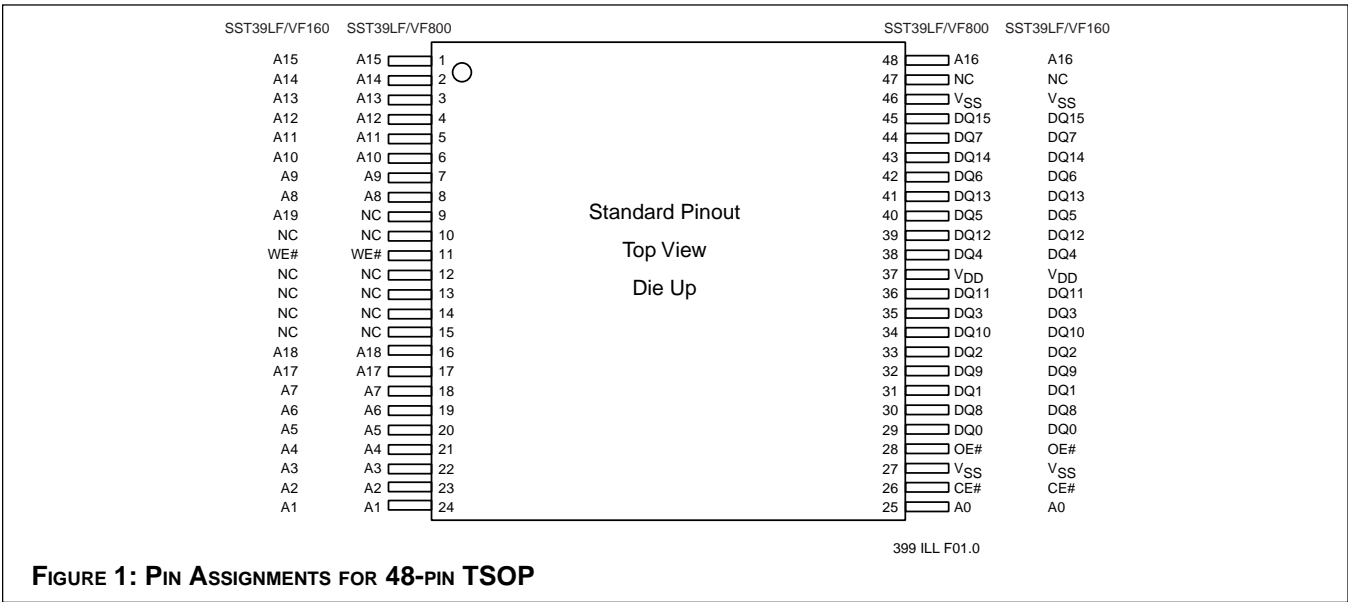
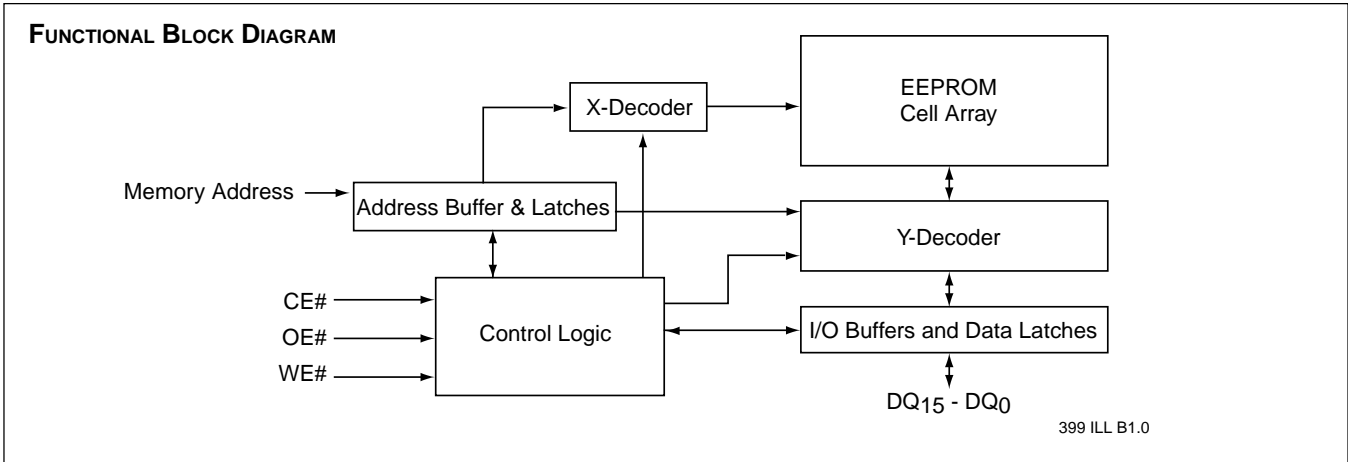

FIGURE 1: PIN ASSIGNMENTS FOR 48-PIN TSOP

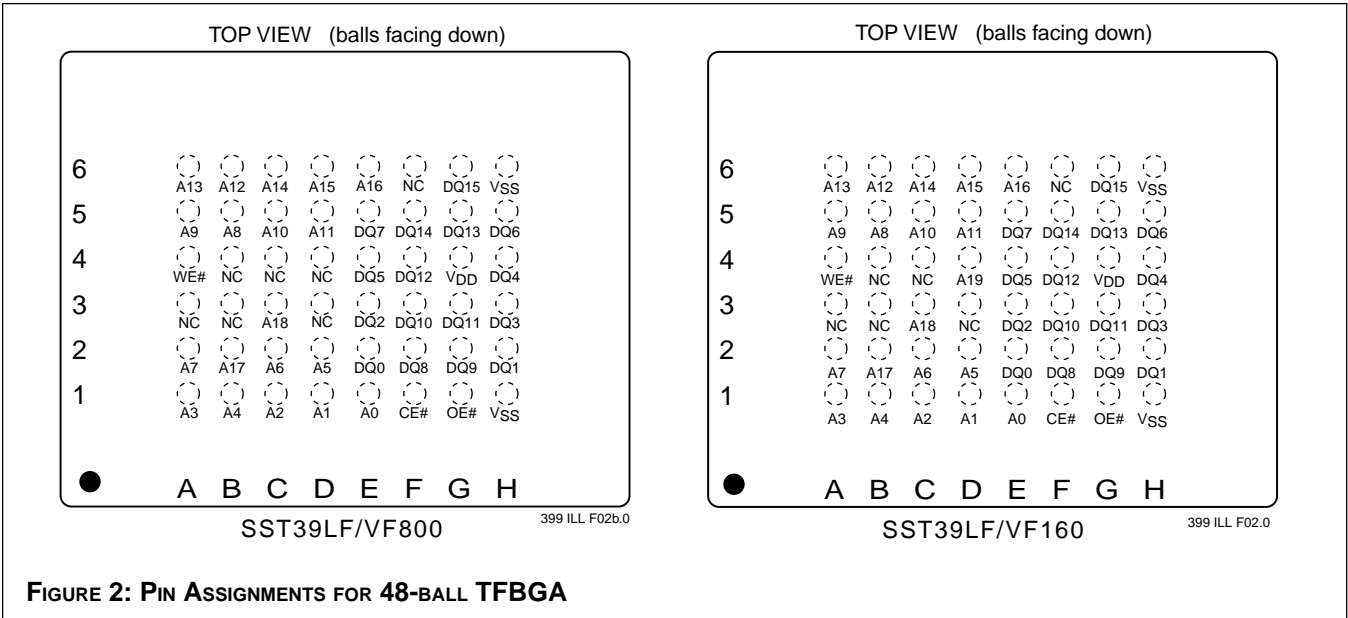

FIGURE 2: PIN ASSIGNMENTS FOR 48-BALL TFBGA



8 Mbit / 16 Mbit Multi-Purpose Flash

SST39LF800 / SST39LF160 / SST39VF800 / SST39VF160

Data Sheet

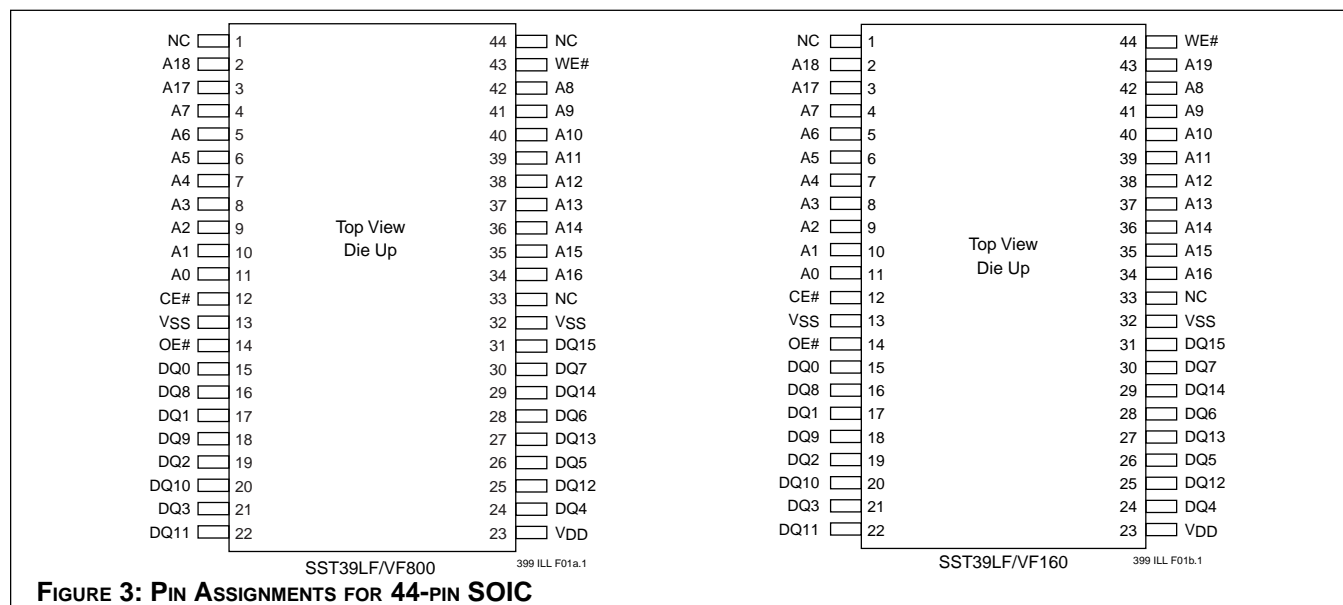

FIGURE 3: PIN ASSIGNMENTS FOR 44-PIN SOIC

TABLE 2: PIN DESCRIPTION

Symbol	Pin Name	Functions
A _{MS} -A ₀	Address Inputs	To provide memory addresses. During Sector-Erase A _{MS} -A ₁₁ address lines will select the sector. During Block-Erase A _{MS} -A ₁₅ address lines will select the block.
DQ ₁₅ -DQ ₀	Data Input/output	To output data during Read cycles and receive input data during Write cycles. Data is internally latched during a write cycle. The outputs are in tri-state when OE# or CE# is high.
CE#	Chip Enable	To activate the device when CE# is low.
OE#	Output Enable	To gate the data output buffers.
WE#	Write Enable	To control the Write operations.
V _{DD}	Power Supply	To provide power supply voltage: 3.0-3.6V for SST39LF800/160 2.7-3.6V for SST39VF800/160
V _{SS}	Ground	
NC	No Connection	Unconnected pins.

Note: A_{MS} = Most significant address
A_{MS} = A₁₈ for SST39LF/VF800 and A₁₉ for SST39LF/VF160

399 PGM T2.1

TABLE 3: OPERATION MODES SELECTION

Mode	CE#	OE#	WE#	A ₉	DQ	Address
Read	V _{IL}	V _{IL}	V _{IH}	A _{IN}	D _{OUT}	A _{IN}
Program	V _{IL}	V _{IH}	V _{IL}	A _{IN}	D _{IN}	A _{IN}
Erase	V _{IL}	V _{IH}	V _{IL}	X	X	Sector or block address, XXh for Chip-Erase
Standby	V _{IH}	X	X	X	High Z	X
Write Inhibit	X	V _{IL}	X	X	High Z/ D _{OUT}	X
	X	X	V _{IH}	X	High Z/ D _{OUT}	X
Product Identification						
Hardware Mode	V _{IL}	V _{IL}	V _{IH}	V _H	Manufacturer Code (00BF)	A _{MS} ⁽²⁾ - A ₁ = V _{IL} , A ₀ = V _{IL}
Software Mode	V _{IL}	V _{IL}	V _{IH}	A _{IN}	Device Code (1)	A _{MS} ⁽²⁾ - A ₁ = V _{IL} , A ₀ = V _{IH} See Table 4

Note: (1) Device Code 2781 for SST39LF/VF800 and 2782 for SST39LF/VF160
(2) A_{MS} = Most significant address
A_{MS} = A₁₈ for SST39LF/VF800 and A₁₉ for SST39LF/VF160

399 PGM T3.0



8 Mbit / 16 Mbit Multi-Purpose Flash SST39LF800 / SST39LF160 / SST39VF800 / SST39VF160

Data Sheet

TABLE 4: SOFTWARE COMMAND SEQUENCE

Command Sequence	1st Bus Write Cycle		2nd Bus Write Cycle		3rd Bus Write Cycle		4th Bus Write Cycle		5th Bus Write Cycle		6th Bus Write Cycle	
	Addr ⁽¹⁾	Data	Addr ⁽¹⁾	Data	Addr ⁽¹⁾	Data	Addr ⁽¹⁾	Data	Addr ⁽¹⁾	Data	Addr ⁽¹⁾	Data
Word-Program	5555H	AAH	2AAAH	55H	5555H	A0H	WA ⁽³⁾	Data				
Sector-Erase	5555H	AAH	2AAAH	55H	5555H	80H	5555H	AAH	2AAAH	55H	SA _x ⁽²⁾	30H
Block-Erase	5555H	AAH	2AAAH	55H	5555H	80H	5555H	AAH	2AAAH	55H	BA _x ⁽²⁾	50H
Chip-Erase	5555H	AAH	2AAAH	55H	5555H	80H	5555H	AAH	2AAAH	55H	5555H	10H
Software ID Entry	5555H	AAH	2AAAH	55H	5555H	90H						
CFI Query Entry	5555H	AAH	2AAAH	55H	5555H	98H						
Software ID Exit/ CFI Exit	XXH	F0H										
Software ID Exit/ CFI Exit	5555H	AAH	2AAAH	55H	5555H	F0H						

399 PGM T4.0

- Notes:**
- (1) Address format A₁₄-A₀ (Hex).
Addresses A₁₅, A₁₆, A₁₇, and A₁₈ are "Don't Care" for Command sequence for SST39LF/VF800.
Addresses A₁₅, A₁₆, A₁₇, A₁₈ and A₁₉ are "Don't Care" for Command sequence for SST39LF/VF160.
 - (2) SA_x for Sector-Erase; uses A_{MS}-A₁₁ address lines
BA_x, for Block-Erase; uses A_{MS}-A₁₅ address lines
A_{MS} = Most significant address
A_{MS} = A₁₈ for SST39LF/VF800 and A₁₉ for SST39LF/VF160
 - (3) WA = Program word address
 - (4) Both Software ID Exit operations are equivalent
 - (5) DQ₁₅ - DQ₈ are "Don't Care" for Command sequence
 - (6) With A_{MS}-A₁=0; SST Manufacturer Code = 00BFH, is read with A₀ = 0,
SST39LF/VF800 Device Code = 2781H, is read with A₀ = 1.
SST39LF/VF160 Device Code = 2782H, is read with A₀ = 1.
A_{MS} = Most significant address
A_{MS} = A₁₈ for SST39LF/VF800 and A₁₉ for SST39LF/VF160
 - (7) The device does not remain in Software Product ID Mode if powered down.

TABLE 5: CFI QUERY IDENTIFICATION STRING¹ FOR SST39LF/VF800 AND SST39LF/VF160

Address	Data	Data
10H 11H 12H	0051H 0052H 0059H	Query Unique ASCII string "QRY"
13H 14H	0001H 0007H	Primary OEM command set
15H 16H	0000H 0000H	Address for Primary Extended Table
17H 18H	0000H 0000H	Alternate OEM command set (00H = none exists)
19H 1AH	0000H 0000H	Address for Alternate OEM extended Table (00H = none exists)

Note 1: Refer to CFI publication 100 for more details.

399 PGM T5.0



8 Mbit / 16 Mbit Multi-Purpose Flash

SST39LF800 / SST39LF160 / SST39VF800 / SST39VF160

Data Sheet

TABLE 6: SYSTEM INTERFACE INFORMATION FOR SST39LF/VF800 AND SST39LF/VF160

Address	Data	Data
1BH	0027H ⁽¹⁾ 0030H ⁽¹⁾	V _{DD} Min. (Program/Erase) DQ7-DQ4: Volts, DQ3-DQ0: 100 millivolts
1CH	0036H	V _{DD} Max. (Program/Erase) DQ7-DQ4: Volts, DQ3-DQ0: 100 millivolts
1DH	0000H	V _{PP} min. (00H = no V _{PP} pin)
1EH	0000H	V _{PP} max. (00H = no V _{PP} pin)
1FH	0004H	Typical time out for Word-Program 2 ^N μs (2 ⁴ = 16 μs)
20H	0000H	Typical time out for min. size buffer program 2 ^N μs (00H = not supported)
21H	0004H	Typical time out for individual Sector/Block-Erase 2 ^N ms (2 ⁴ = 16 ms)
22H	0006H	Typical time out for Chip-Erase 2 ^N ms (2 ⁶ = 64 ms)
23H	0001H	Maximum time out for Word-Program 2 ^N times typical (2 ¹ x 2 ⁴ = 32 μs)
24H	0000H	Maximum time out for buffer program 2 ^N times typical
25H	0001H	Maximum time out for individual Sector/Block-Erase 2 ^N times typical (2 ¹ x 2 ⁴ = 32 ms)
26H	0001H	Maximum time out for Chip-Erase 2 ^N times typical (2 ¹ x 2 ⁶ = 128 ms)

Note: (1) 0030H for SST39LF800/160 and 0027H for SST39VF800/160

399 PGM T6.1

TABLE 7A: DEVICE GEOMETRY INFORMATION FOR SST39LF/VF800

Address	Data	Data
27H	0014H	Device size = 2 ^N Bytes (14H = 20; 2 ²⁰ = 1M Bytes)
28H 29H	0001H 0000H	Flash Device Interface description; 0001H = x16-only asynchronous interface
2AH 2BH	0000H 0000H	Maximum number of byte in multi-byte write = 2 ^N (00H = not supported)
2CH	0002H	Number of Erase Sector/Block sizes supported by device
2DH 2EH 2FH 30H	00FFH 0000H 0010H 0000H	Sector Information (y + 1 = Number of sectors; z x 256B = sector size) y = 255 + 1 = 256 sectors (00FFH = 255) z = 16 x 256 Bytes = 4 KBytes/sector (0010H = 16)
31H 32H 33H 34H	000FH 0000H 0000H 0001H	Block Information (y + 1 = Number of blocks; z x 256B = block size) y = 15 + 1 = 16 blocks (000FH = 15) z = 256 x 256 Bytes = 64 KBytes/block (0100H = 256)

399 PGM T7a.0

TABLE 7B: DEVICE GEOMETRY INFORMATION FOR SST39LF/VF160

Address	Data	Data
27H	0015H	Device size = 2 ^N Byte (15H = 21; 2 ²¹ = 2M Bytes)
28H 29H	0001H 0000H	Flash Device Interface description; 0001H = x16-only asynchronous interface
2AH 2BH	0000H 0000H	Maximum number of byte in multi-byte write = 2 ^N (00H = not supported)
2CH	0002H	Number of Erase Sector/Block sizes supported by device
2DH 2EH 2FH 30H	00FFH 0001H 0010H 0000H	Sector Information (y + 1 = Number of sectors; z x 256B = sector size) y = 511 + 1 = 512 sectors (01FF = 511) z = 16 x 256 Bytes = 4 KBytes/sector (0010H = 16)
31H 32H 33H 34H	001FH 0000H 0000H 0001H	Block Information (y + 1 = Number of blocks; z x 256B = block size) y = 31 + 1 = 32 blocks (001F = 31) z = 256 x 256 Bytes = 64 KBytes/block (0100H = 256)

399 PGM T7.0



8 Mbit / 16 Mbit Multi-Purpose Flash

SST39LF800 / SST39LF160 / SST39VF800 / SST39VF160

Data Sheet

TABLE 8: DC OPERATING CHARACTERISTICS

V_{DD} = 3.0-3.6V FOR SST39LF800/160 AND 2.7-3.6V FOR SST39VF800/160

Symbol	Parameter	Limits			Test Conditions
		Min	Max	Units	
I _{DD}	Power Supply Current Read Program and Erase		20 25	mA mA	CE#=OE#=V _{IL} , WE#=V _{IH} , all I/Os open, Address input = V _{IL} /V _{IH} , at f=1/T _{RC} Min. CE#=WE#=V _{IL} , OE#=V _{IH} , V _{DD} =V _{DD} Max.
I _{SB}	Standby V _{DD} Current		20	μA	CE#=V _{IHC} , V _{DD} = V _{DD} Max.
I _{ALP}	Auto Low Power Current		20	μA	CE#=V _{ILC} , V _{DD} = V _{DD} Max., all inputs = V _{IHC} or V _{ILC} , WE# = V _{IHC}
I _{LI}	Input Leakage Current		1	μA	V _{IN} =GND to V _{DD} , V _{DD} = V _{DD} Max.
I _{LO}	Output Leakage Current		1	μA	V _{OUT} =GND to V _{DD} , V _{DD} = V _{DD} Max.
V _{IL}	Input Low Voltage		0.8	V	V _{DD} = V _{DD} Min.
V _{ILC}	Input Low Voltage (CMOS)		0.3	V	V _{DD} = V _{DD} Max.
V _{IH}	Input High Voltage	0.7 V _{DD}		V	V _{DD} = V _{DD} Max.
V _{IHC}	Input High Voltage (CMOS)	V _{DD} -0.3		V	V _{DD} = V _{DD} Max.
V _{OL}	Output Low Voltage		0.2	V	I _{OL} = 100 μA, V _{DD} = V _{DD} Min.
V _{OH}	Output High Voltage	V _{DD} -0.2		V	I _{OH} = -100 μA, V _{DD} = V _{DD} Min.
V _H	Supervoltage for A ₉ pin	11.4	12.6	V	CE# = OE# =V _{IL} , WE# = V _{IH}
I _H	Supervoltage Current for A ₉ pin		200	μA	CE# = OE# = V _{IL} , WE# = V _{IH} , A ₉ = V _H Max.

399 PGM T9.0

TABLE 9: RECOMMENDED SYSTEM POWER-UP TIMINGS

Symbol	Parameter	Minimum	Units
T _{PU-READ} ⁽¹⁾	Power-up to Read Operation	100	μs
T _{PU-WRITE} ⁽¹⁾	Power-up to Program/Erase Operation	100	μs

399 PGM T10.0

Note: ⁽¹⁾ This parameter is measured only for initial qualification and after a design or process change that could affect this parameter.

TABLE 10: CAPACITANCE (T_a = 25 °C, f=1 Mhz, other pins open)

Parameter	Description	Test Condition	Maximum
C _{I/O} ⁽¹⁾	I/O Pin Capacitance	V _{I/O} = 0V	12 pF
C _{IN} ⁽¹⁾	Input Capacitance	V _{IN} = 0V	6 pF

399 PGM T11.0

Note: ⁽¹⁾ This parameter is measured only for initial qualification and after a design or process change that could affect this parameter.

TABLE 11: RELIABILITY CHARACTERISTICS

Symbol	Parameter	Minimum Specification	Units	Test Method
N _{END} ⁽¹⁾	Endurance	10,000	Cycles	JEDEC Standard A117
T _{DR} ⁽¹⁾	Data Retention	100	Years	JEDEC Standard A103
V _{ZAP_HBM} ⁽¹⁾	ESD Susceptibility Human Body Model	2000	Volts	JEDEC Standard A114
V _{ZAP_MM} ⁽¹⁾	ESD Susceptibility Machine Model	200	Volts	JEDEC Standard A115
I _{LTH} ⁽¹⁾	Latch Up	100 + I _{DD}	mA	JEDEC Standard 78

399 PGM T12.0

Note: ⁽¹⁾ This parameter is measured only for initial qualification and after a design or process change that could affect this parameter.



8 Mbit / 16 Mbit Multi-Purpose Flash SST39LF800 / SST39LF160 / SST39VF800 / SST39VF160

Data Sheet

AC CHARACTERISTICS

TABLE 12: READ CYCLE TIMING PARAMETERS

$V_{DD} = 3.0-3.6V$ FOR SST39LF800/160 AND $V_{DD} = 2.7-3.6V$ FOR SST39VF800/160

Symbol	Parameter	SST39LF800/160-55		SST39VF800/160-70		SST39VF800/160-90		Units
		Min	Max	Min	Max	Min	Max	
T_{RC}	Read Cycle Time	55		70		90		ns
T_{CE}	Chip Enable Access Time		55		70		90	ns
T_{AA}	Address Access Time		55		70		90	ns
T_{OE}	Output Enable Access Time		30		35		45	ns
$T_{CLZ}^{(1)}$	CE# Low to Active Output	0		0		0		ns
$T_{OLZ}^{(1)}$	OE# Low to Active Output	0		0		0		ns
$T_{CHZ}^{(1)}$	CE# High to High-Z Output		15		20		30	ns
$T_{OHZ}^{(1)}$	OE# High to High-Z Output		15		20		30	ns
$T_{OH}^{(1)}$	Output Hold from Address Change	0		0		0		ns

399 PGM T13.1

Note: (1) This parameter is measured only for initial qualification and after the design or process change that could affect this parameter.

TABLE 13: PROGRAM/ERASE CYCLE TIMING PARAMETERS

Symbol	Parameter	Min	Max	Units
T_{BP}	Word-Program Time		20	μs
T_{AS}	Address Setup Time	0		ns
T_{AH}	Address Hold Time	30		ns
T_{CS}	WE# and CE# Setup Time	0		ns
T_{CH}	WE# and CE# Hold Time	0		ns
T_{OES}	OE# High Setup Time	0		ns
T_{OEH}	OE# High Hold Time	10		ns
T_{CP}	CE# Pulse Width	40		ns
T_{WP}	WE# Pulse Width	40		ns
$T_{WPH}^{(1)}$	WE# Pulse Width High	30		ns
$T_{CPH}^{(1)}$	CE# Pulse Width High	30		ns
T_{DS}	Data Setup Time	30		ns
$T_{DH}^{(1)}$	Data Hold Time	0		ns
$T_{IDA}^{(1)}$	Software ID Access and Exit Time		150	ns
T_{SE}	Sector-Erase		25	ms
T_{BE}	Block-Erase		25	ms
T_{SCE}	Chip-Erase		100	ms

399 PGM T14.0

Note: (1) This parameter is measured only for initial qualification and after the design or process change that could affect this parameter.



8 Mbit / 16 Mbit Multi-Purpose Flash

SST39LF800 / SST39LF160 / SST39VF800 / SST39VF160

Data Sheet

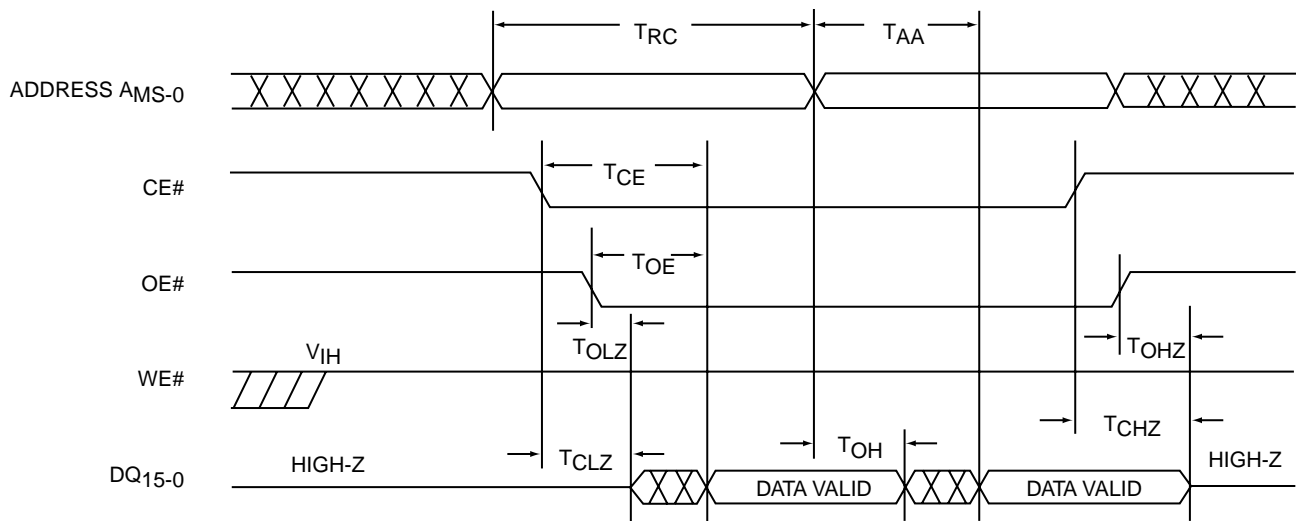

Note: AMS = Most significant address
AMS = A₁₈ for SST39LF/VF800 and A₁₉ for SST39LF/VF160

399 ILL F03.0

FIGURE 4: READ CYCLE TIMING DIAGRAM

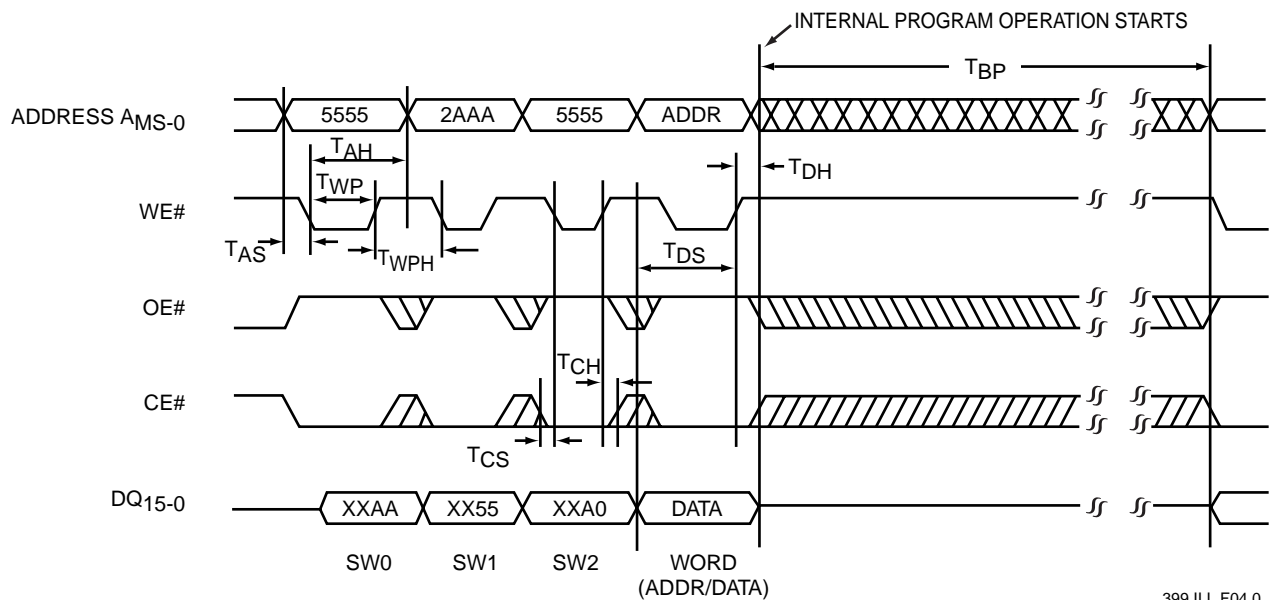

Note: AMS = Most significant address
AMS = A₁₈ for SST39LF/VF800 and A₁₉ for SST39LF/VF160

399 ILL F04.0

FIGURE 5: WE# CONTROLLED PROGRAM CYCLE TIMING DIAGRAM



8 Mbit / 16 Mbit Multi-Purpose Flash SST39LF800 / SST39LF160 / SST39VF800 / SST39VF160

Data Sheet

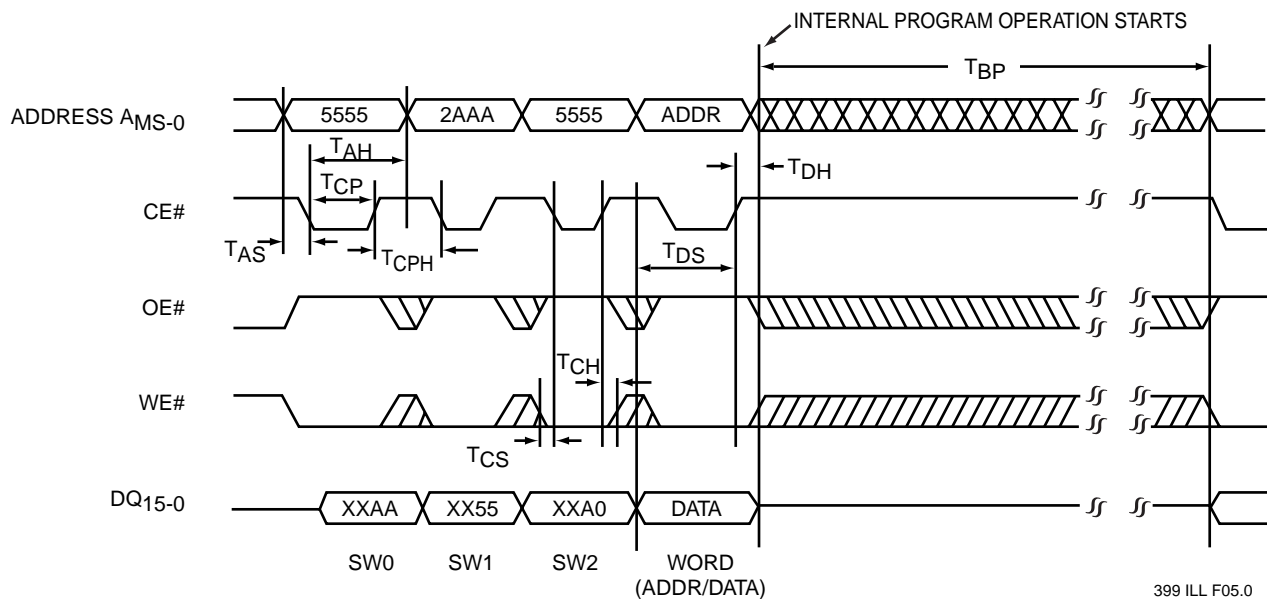

Note: AMS = Most significant address
AMS = A₁₈ for SST39LF/VF800 and A₁₉ for SST39LF/VF160

FIGURE 6: CE# CONTROLLED PROGRAM CYCLE TIMING DIAGRAM

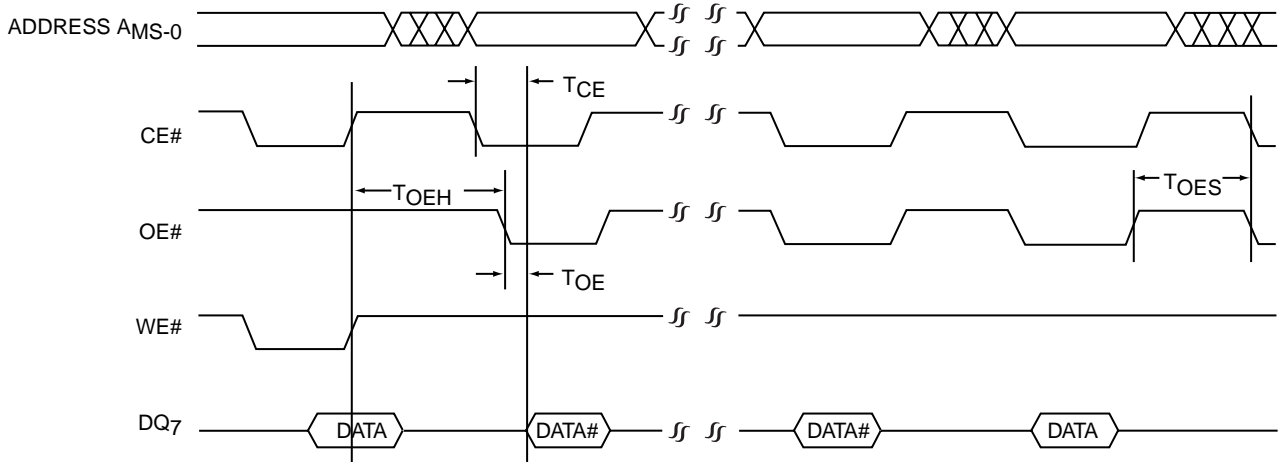

Note: AMS = Most significant address
AMS = A₁₈ for SST39LF/VF800 and A₁₉ for SST39LF/VF160

FIGURE 7: DATA# POLLING TIMING DIAGRAM



8 Mbit / 16 Mbit Multi-Purpose Flash

SST39LF800 / SST39LF160 / SST39VF800 / SST39VF160

Data Sheet

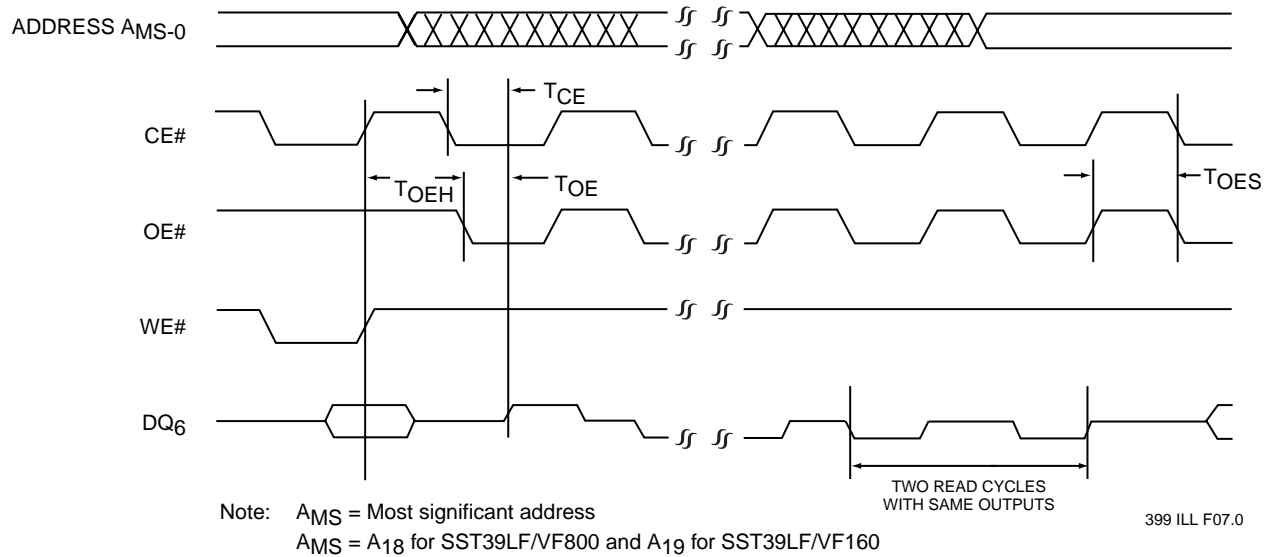
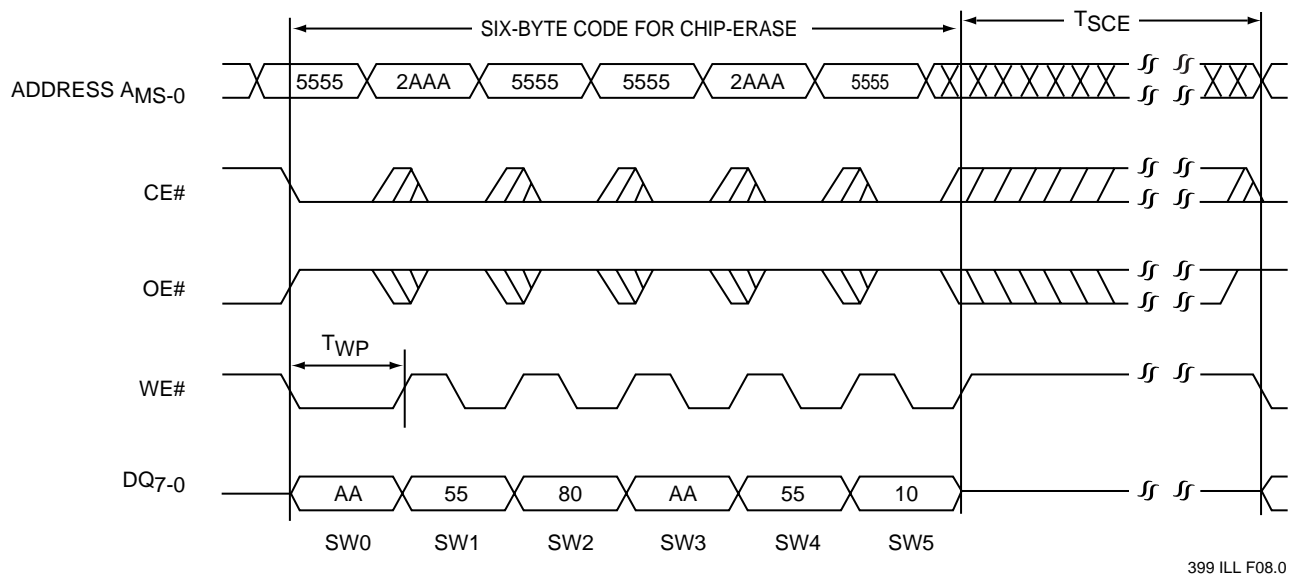

FIGURE 8: TOGGLE BIT TIMING DIAGRAM



Note: This device also supports CE# controlled Chip-Erase operation. The WE# and CE# signals are interchangeable as long as minimum timings are met. (See Table 13)
 AMS = Most significant address
 AMS = A18 for SST39LF/VF800 and A19 for SST39LF/VF160

FIGURE 9: WE# CONTROLLED CHIP-ERASE TIMING DIAGRAM



8 Mbit / 16 Mbit Multi-Purpose Flash SST39LF800 / SST39LF160 / SST39VF800 / SST39VF160

Data Sheet

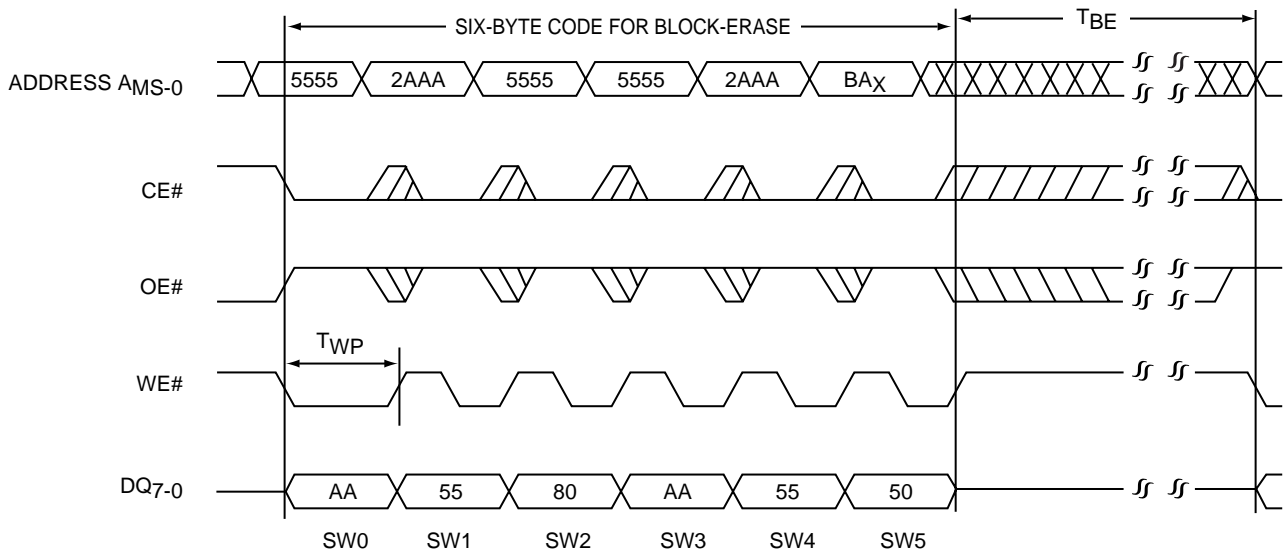

Note: This device also supports CE# controlled Block-Erase operation. The WE# and CE# signals are interchangeable as long as minimum timings are met. (See Table 13)
 BA_x = Block Address
 AMS = Most significant address
 AMS = A₁₈ for SST39LF/VF800 and A₁₉ for SST39LF/VF160

FIGURE 10: WE# CONTROLLED BLOCK-ERASE TIMING DIAGRAM

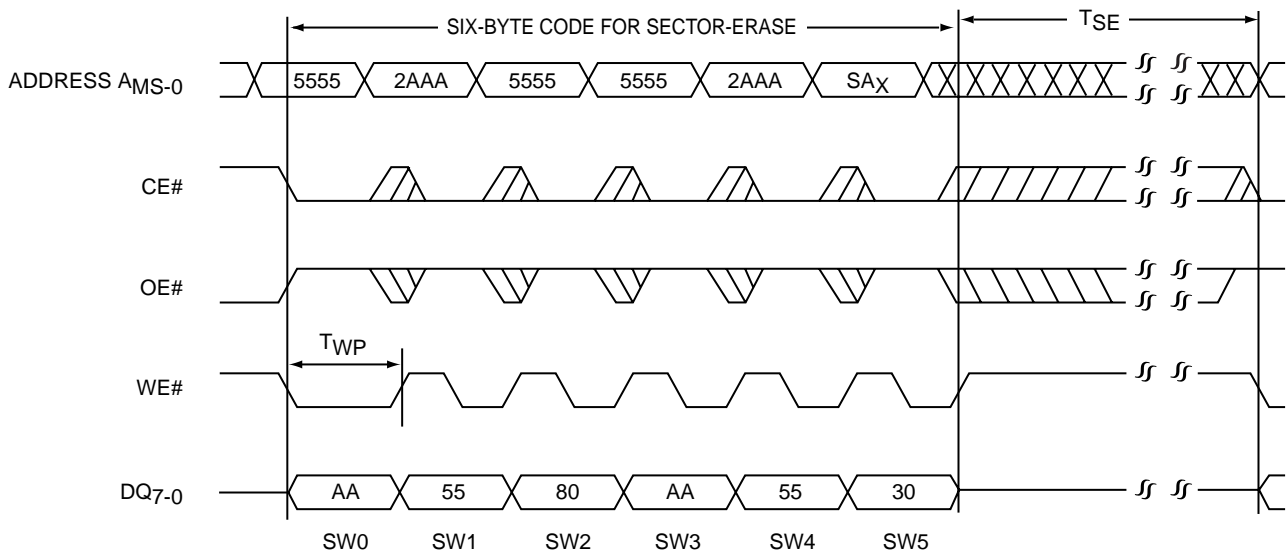

Note: This device also supports CE# controlled Sector-Erase operation. The WE# and CE# signals are interchangeable as long as minimum timings are met. (See Table 13)
 SA_x = Sector Address
 AMS = Most significant address
 AMS = A₁₈ for SST39LF/VF800 and A₁₉ for SST39LF/VF160

FIGURE 11: WE# CONTROLLED SECTOR-ERASE TIMING DIAGRAM



8 Mbit / 16 Mbit Multi-Purpose Flash SST39LF800 / SST39LF160 / SST39VF800 / SST39VF160

Data Sheet

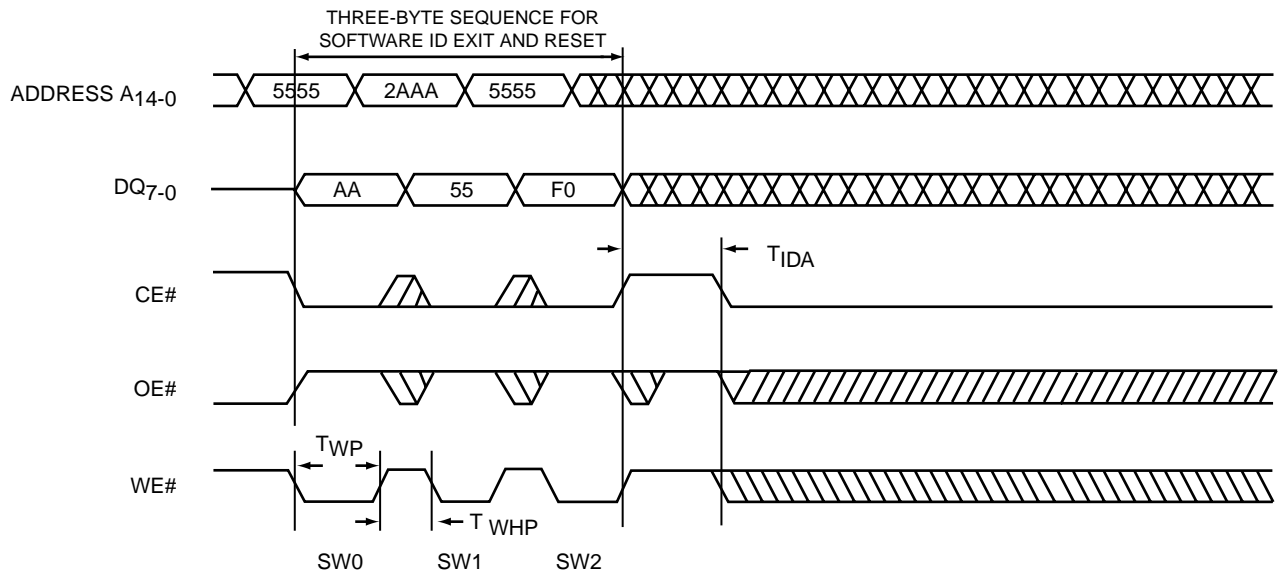

399 ILL F10.0

FIGURE 14: SOFTWARE ID EXIT/CFI EXIT



8 Mbit / 16 Mbit Multi-Purpose Flash SST39LF800 / SST39LF160 / SST39VF800 / SST39VF160

Data Sheet

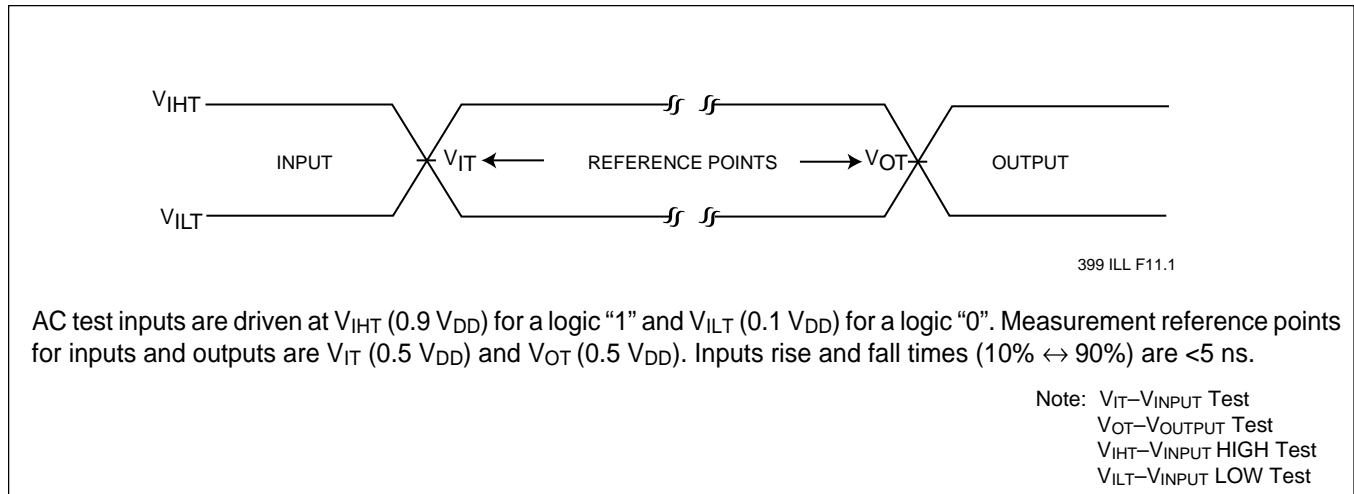

FIGURE 15: AC INPUT/OUTPUT REFERENCE WAVEFORMS

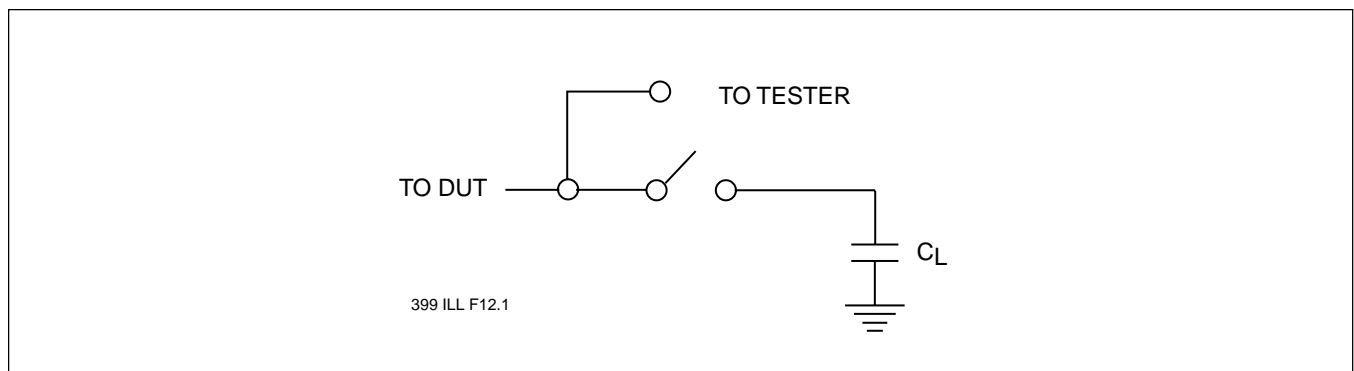

FIGURE 16: A TEST LOAD EXAMPLE

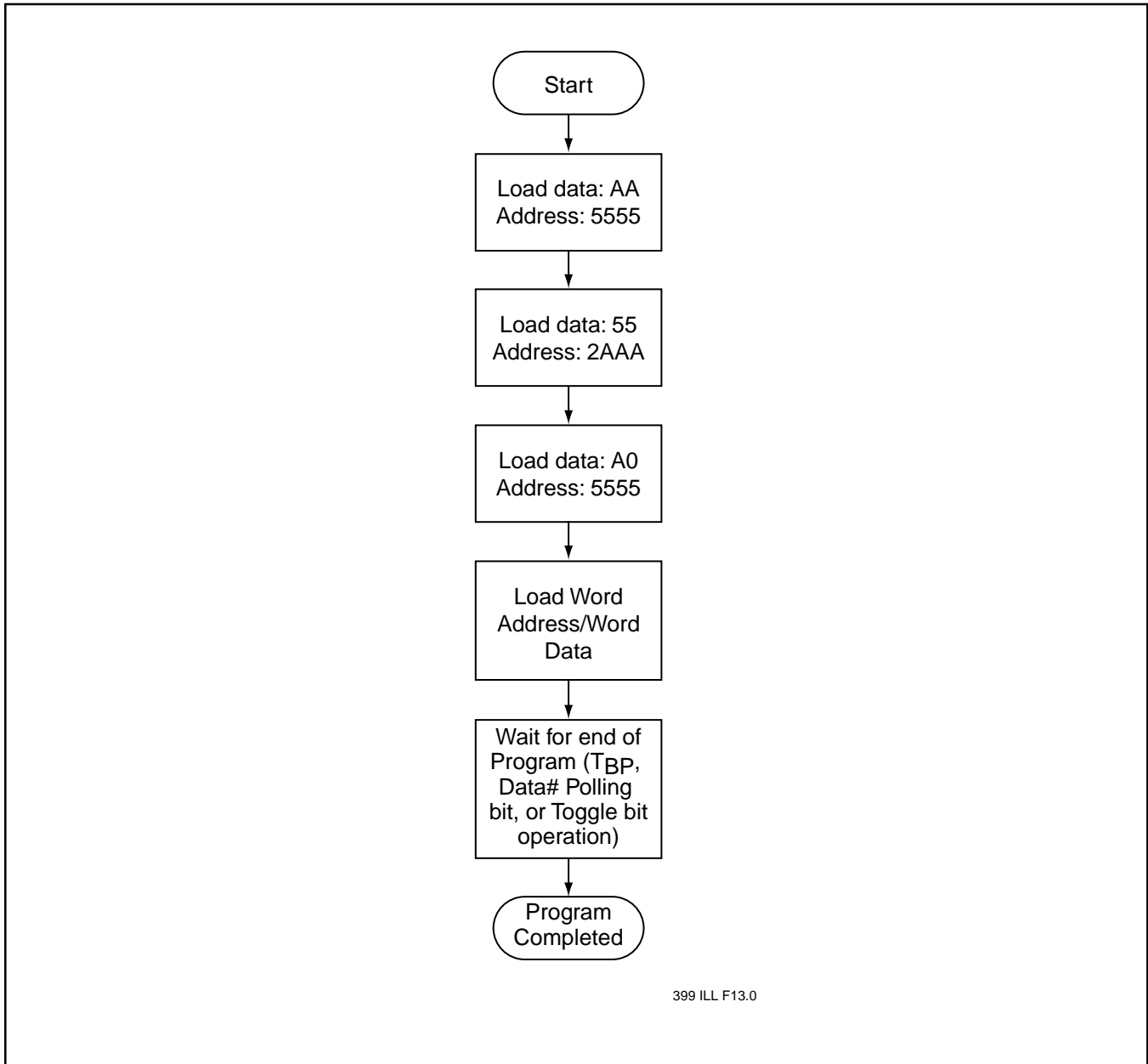

FIGURE 17: WORD-PROGRAM ALGORITHM



8 Mbit / 16 Mbit Multi-Purpose Flash SST39LF800 / SST39LF160 / SST39VF800 / SST39VF160

Data Sheet

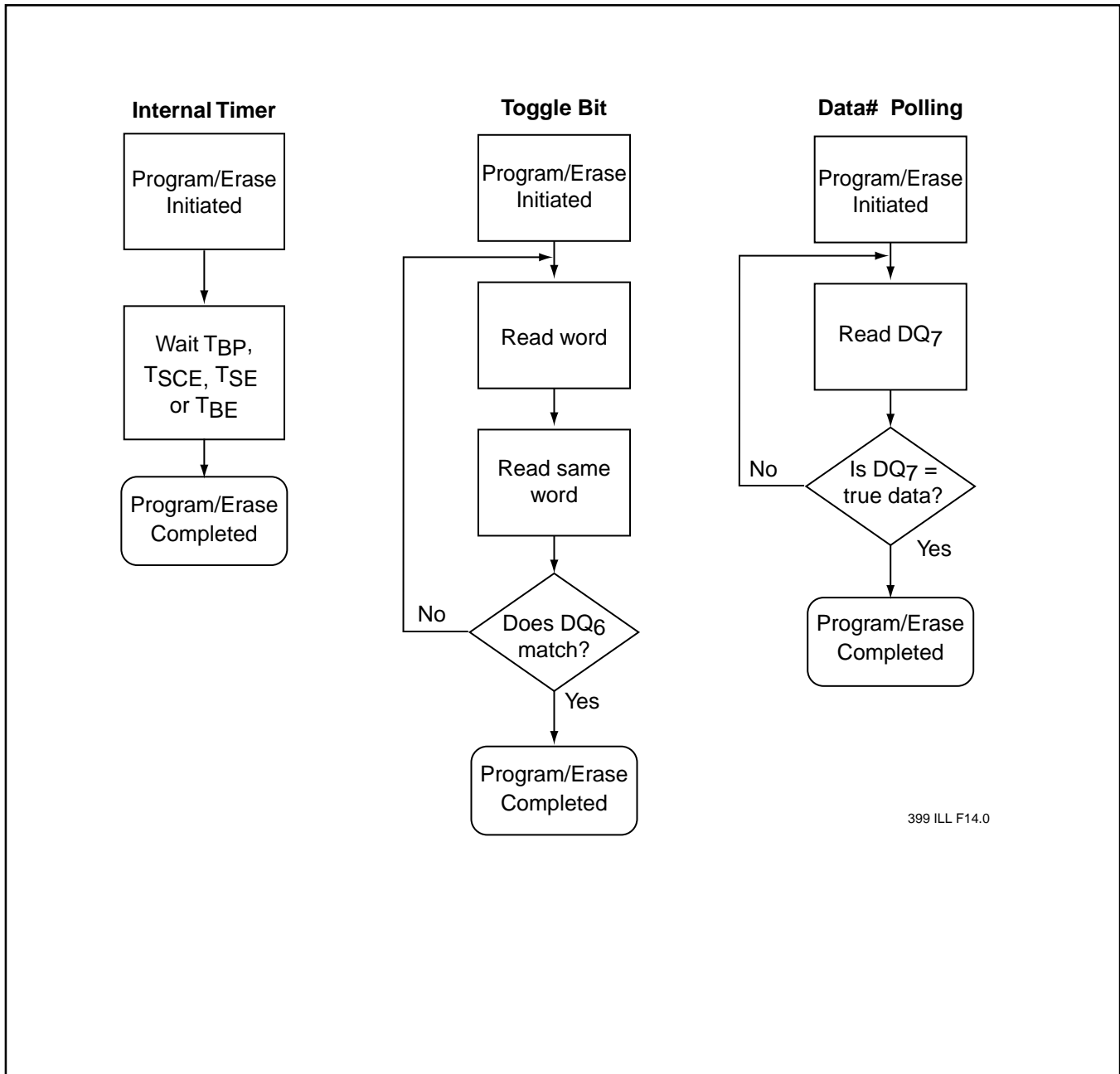

FIGURE 18: WAIT OPTIONS

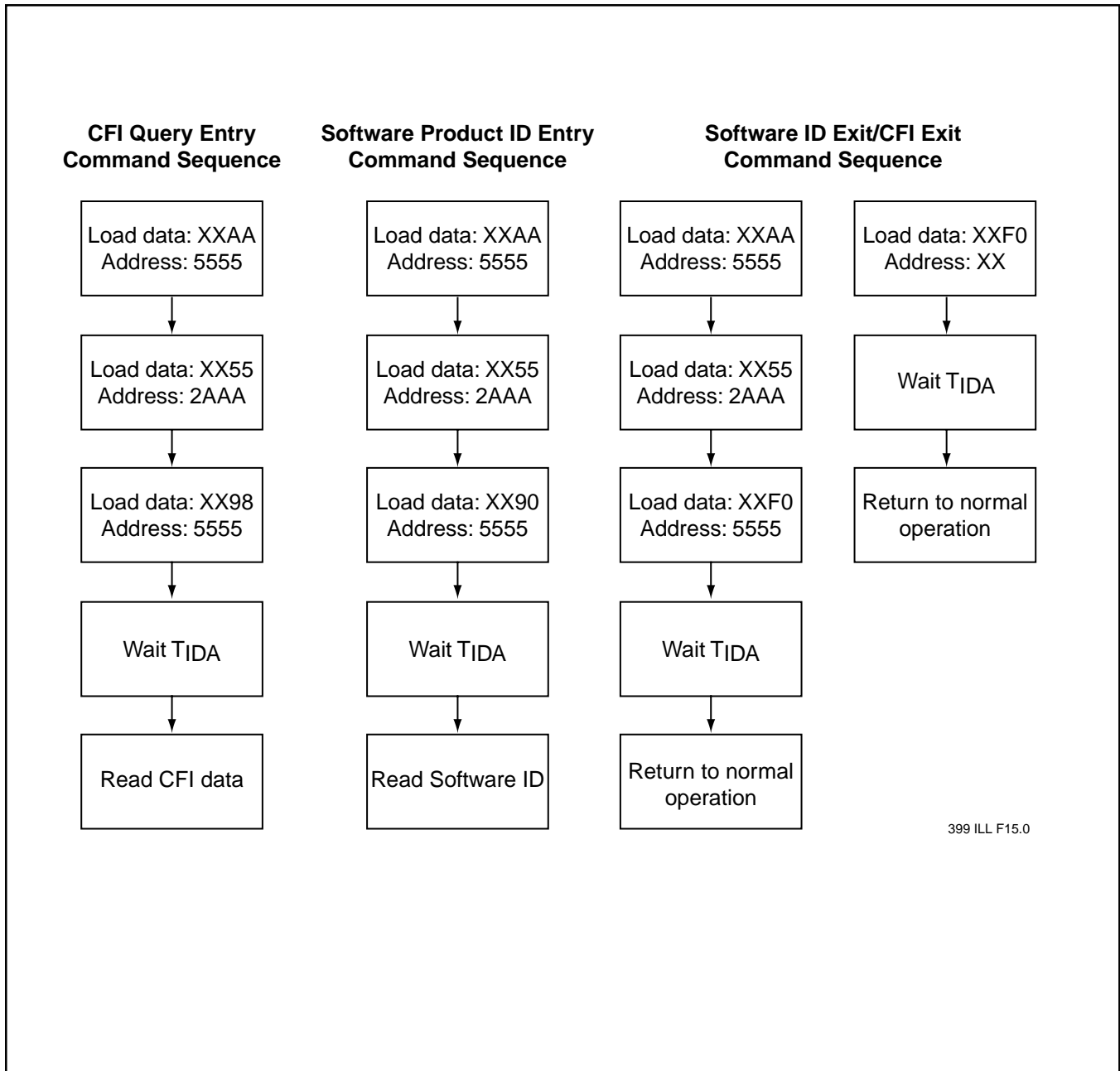

FIGURE 19: SOFTWARE PRODUCT ID/CFI COMMAND FLOWCHARTS



8 Mbit / 16 Mbit Multi-Purpose Flash SST39LF800 / SST39LF160 / SST39VF800 / SST39VF160

Data Sheet

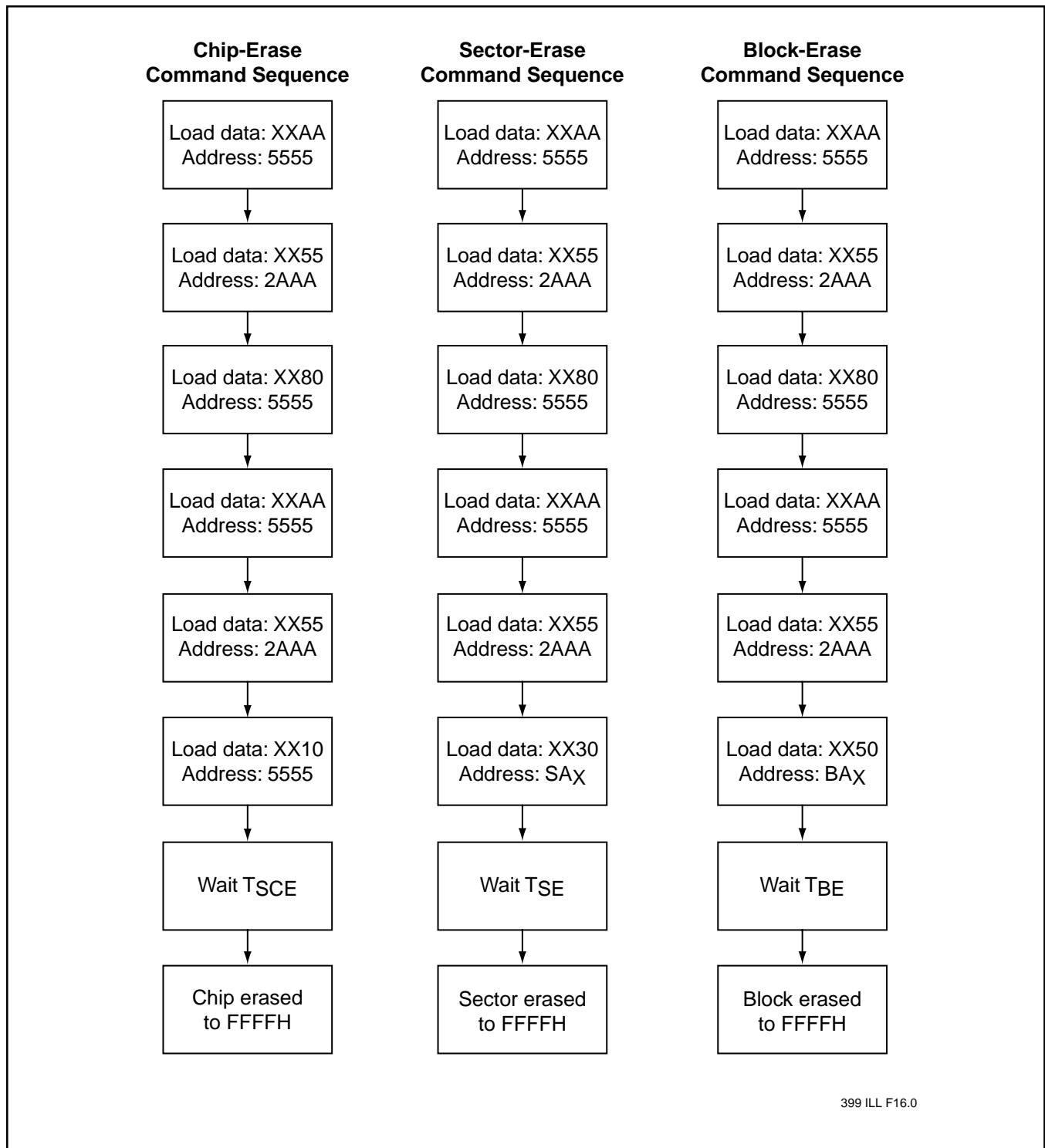
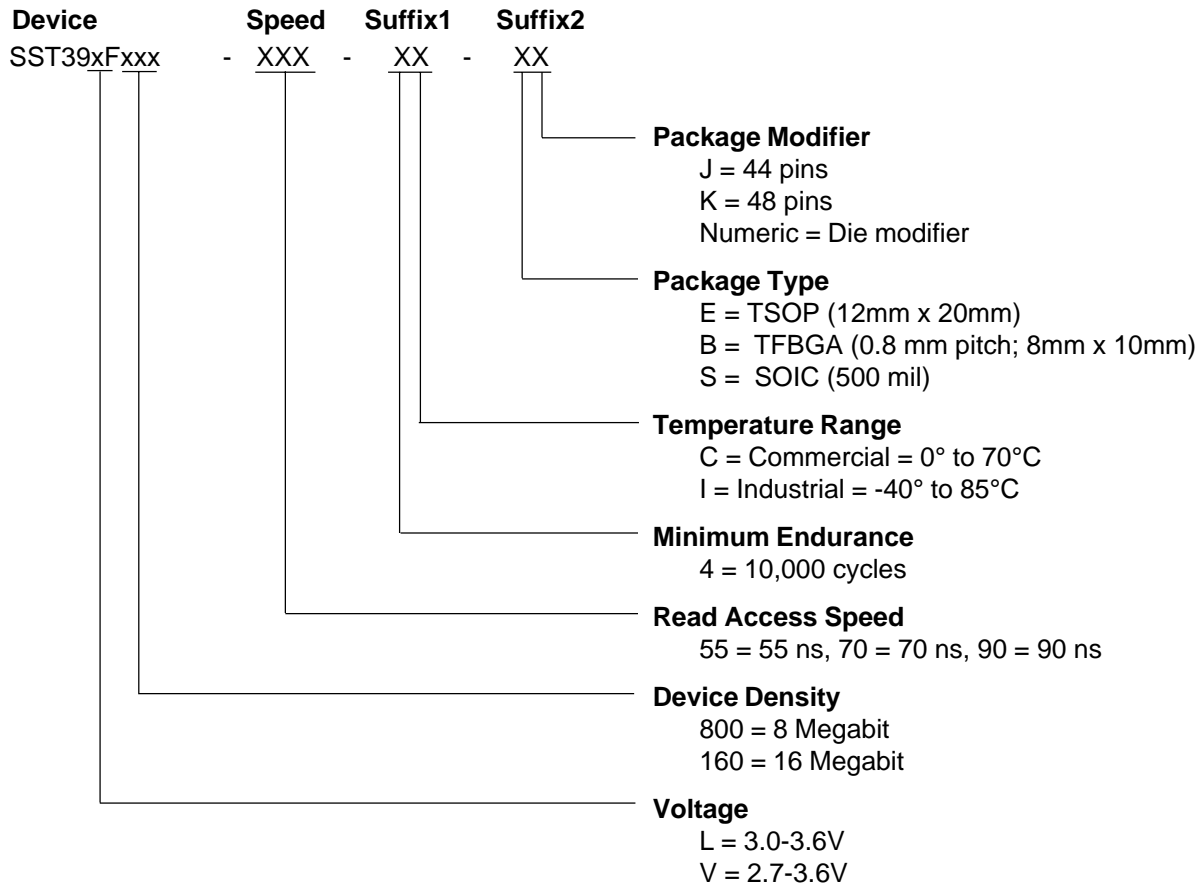

FIGURE 20: ERASE COMMAND SEQUENCE



8 Mbit / 16 Mbit Multi-Purpose Flash SST39LF800 / SST39LF160 / SST39VF800 / SST39VF160

Data Sheet



SST39LF800 Valid combinations

SST39LF800-55-4C-EK SST39LF800-55-4C-BK SST39LF800-55-4C-SJ

SST39VF800 Valid combinations

SST39VF800-70-4C-EK SST39VF800-70-4C-BK SST39VF800-70-4C-SJ
 SST39VF800-90-4C-EK SST39VF800-90-4C-BK SST39VF800-90-4C-SJ
 SST39VF800-70-4I-EK SST39VF800-70-4I-BK SST39VF800-70-4I-SJ
 SST39VF800-90-4I-EK SST39VF800-90-4I-BK SST39VF800-90-4I-SJ

SST39LF160 Valid combinations

SST39LF160-55-4C-EK SST39LF160-55-4C-BK SST39LF160-55-4C-SJ

SST39VF160 Valid combinations

SST39VF160-70-4C-EK SST39VF160-70-4C-BK SST39VF160-70-4C-SJ
 SST39VF160-90-4C-EK SST39VF160-90-4C-BK SST39VF160-90-4C-SJ
 SST39VF160-70-4I-EK SST39VF160-70-4I-BK SST39VF160-70-4I-SJ
 SST39VF160-90-4I-EK SST39VF160-90-4I-BK SST39VF160-90-4I-SJ

Example: Valid combinations are those products in mass production or will be in mass production. Consult your SST sales representative to confirm availability of valid combinations and to determine availability of new combinations.



8 Mbit / 16 Mbit Multi-Purpose Flash SST39LF800 / SST39LF160 / SST39VF800 / SST39VF160

Data Sheet

PACKAGING DIAGRAMS

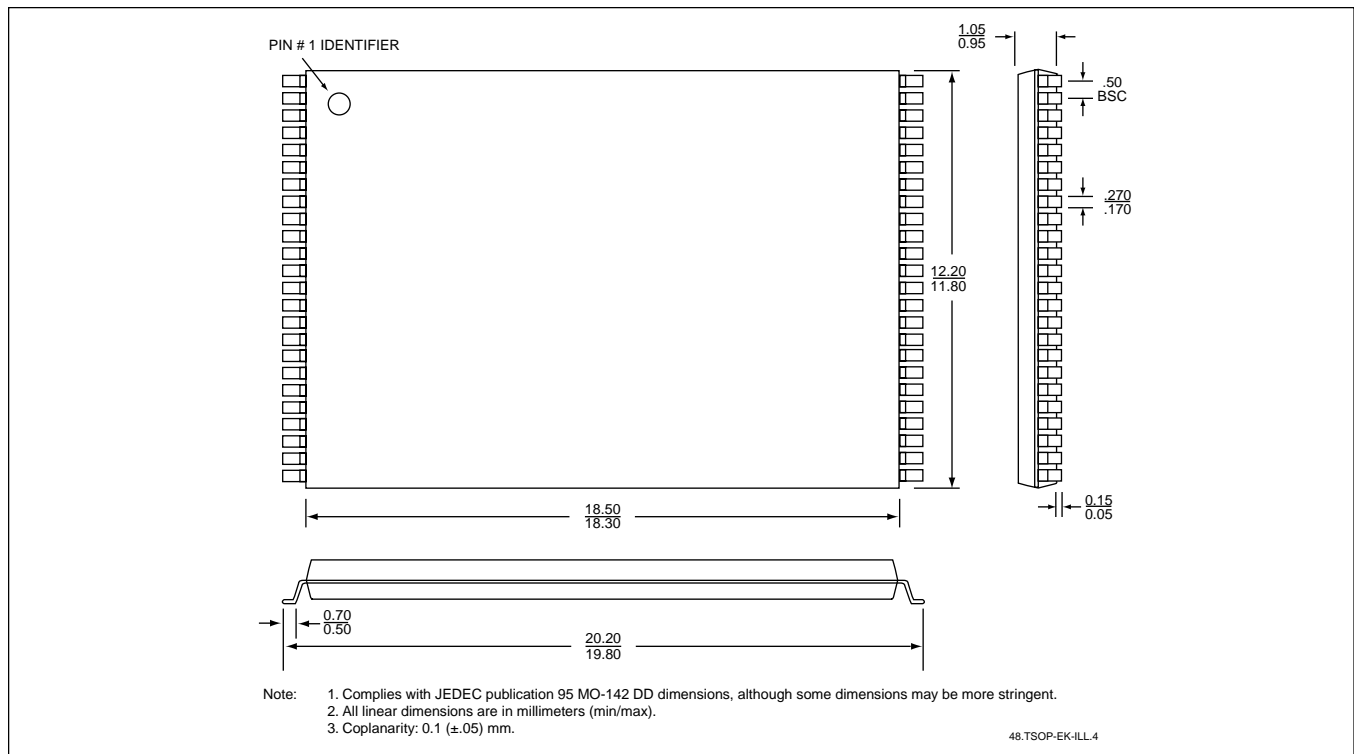

48-PIN THIN SMALL OUTLINE PACKAGE (TSOP) 12MM X 20MM

SST PACKAGE CODE: EK

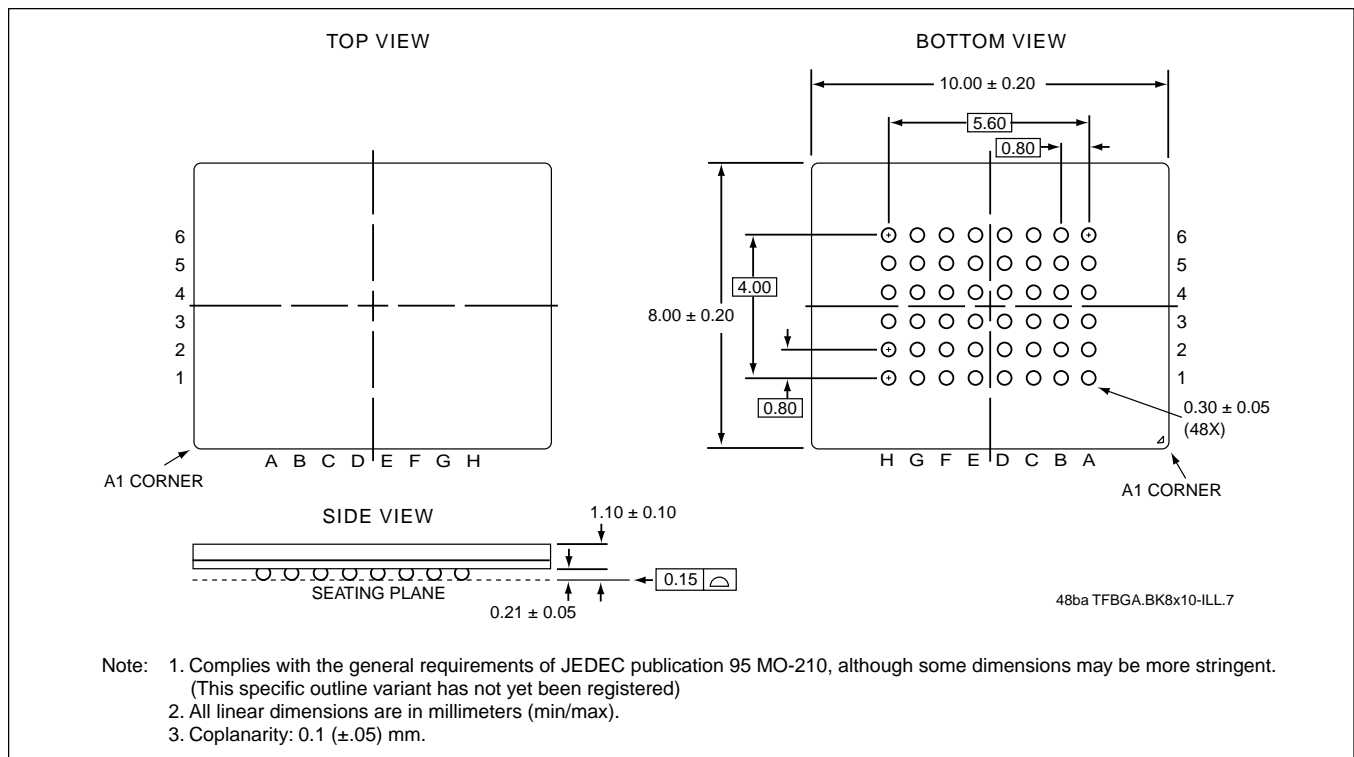

48-BALL THIN PROFILE FINE-PITCH BALL GRID ARRAY (TFBGA) 8MM X 10MM

SST PACKAGE CODE: BK



8 Mbit / 16 Mbit Multi-Purpose Flash SST39LF800 / SST39LF160 / SST39VF800 / SST39VF160

Data Sheet

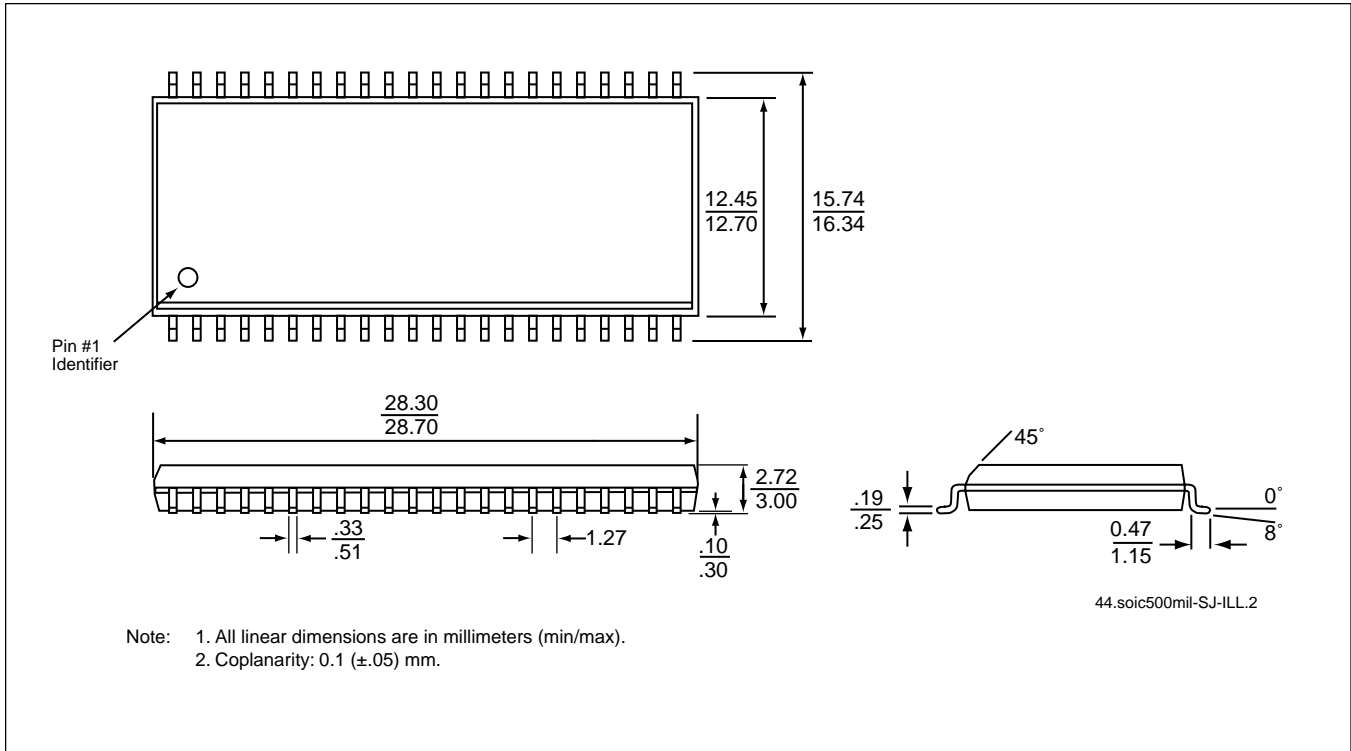

44-PIN SMALL OUTLINE IC (SOIC/500MIL)

SST PACKAGE CODE: SJ