

## Tiny Step-Up DC/DC Converter Design for Portal Single Cell Applications

Stanley Chen

### Abstract

Products such as walkman, pager, electronic dictionary, MP3 player and PDA, none of them can escape out of using one cell trend. This article introduces a high efficiency AIC1638/1639 step-up controller that can boost the voltage of single battery cell up to 3.0V, 3.3V, even to 5.0V. It resolves the problem intend using only one cell in the devices.

### Introduction

AIC1638/1639 is a high efficiency voltage step-up type control IC using PFM (Pulse Frequency Modulation) control technology. It consists of PFM control unit, high-speed error amplifier, precise reference voltage, singleswitching transistor for AIC1638, or push-pull driver output for AIC1639.

Features of AIC1638/1639 : it provides low quiescent current, very high efficiency power conversion, and very low gate threshold voltage. The latter one can guarantee the output voltage up to the required working level even the input voltage is started up at 0.8 V.

Therefore, AIC1638/1639 can use every bit of energy in the cell efficiently to stretch out the cell's lifetime. More importantly, it can work with minimal external elements (such as inductor L, capacitor C and diode D). It perfectly meets the smart requirements for the least number of elements and minimum space (see Figure 1).

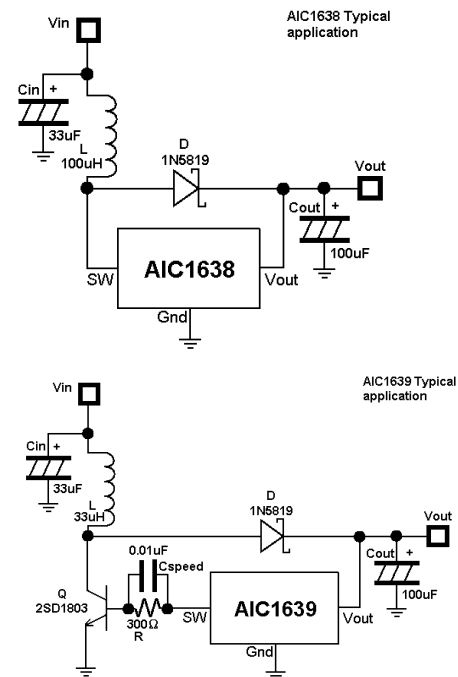
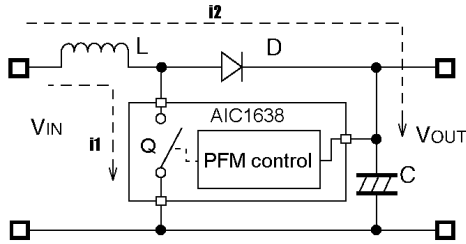

Figure 1 AIC1638/1639 Typical application

### Principle

The following simple diagram is used to illustrate the operating principle of AIC1638/1639.



**Figure 2 AIC1638/1639 feedback control diagram**

In PFM control system, a fixed switch on time ( $t_{ON}$ ) is in cooperating with control oscillator frequency to maintain the output voltage at the required voltage level. As shown in Figure 2, a boost voltage step-up circuit configuration is composed with L, D, Q and C. AIC1638 acts as a central unit to control on/off switching of Q by monitoring the feedback output voltage. Therefore, it can achieve a stable output voltage.

In the following article, The discontinuous conduction operation in step-up converter is illustrated for example of operation principle (assume that  $V_F$  and  $V_{CE}$  are ignored):

1. As Q is turned on, a current  $i_1$  passes through inductor L. Energy is stored in inductor and increasing. During the ON time, current  $i_1$  start at minimum value ( $I_{L,MIN}=0$ ) increasing linearly to maximum  $i_{L,MAX}$ . As the turn-on time ( $t_{ON}$ ) of Q increases, inductor current increase proportionally also.

$$\Delta I = I_{L,MAX} - I_{L,MIN} = \frac{V_{IN} \times t_{ON}}{L} \dots\dots(1)$$

2. At the moment Q is turned off, inductor current maintains at  $i_{L,MAX}$  but inductor voltage polarity inverse instantly and diode D is then forward bias, allowing current in inductor release to load. During the off time of Q, current  $i_2$  decreasing flows from source into output terminal through L and D.
3. Current  $i_2$  decreases down to 0 after  $t_{OPEN}$  time. Diode D is then turned off.

$$\Delta I = I_{L,MAX} - I_{L,MIN} = \frac{(V_{OUT} - V_{IN}) \times t_{OPEN}}{L} \dots(2)$$

4. L, D and Q stay at rest-state to wait for next Q turn on cycle.

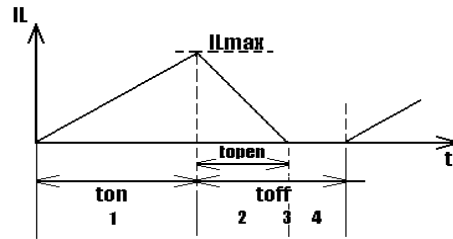

**Figure 3 Inductor current  $i_L$**

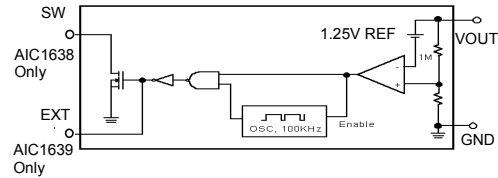

**Figure 4 AIC1638/1639 inside configuration**

### Oscillator

The frequency is designed to be 100KHZ. Typical duty cycle ratio is 75%. On time is calculated :

$$T_{ON} = \frac{D}{f_{osc}} = \frac{0.75}{100KHZ} = 7.5 (\mu s) \dots(3)$$

### Error Comparator

After passing through a series voltage divider resistors, output voltage feeds back is applied to the input terminal of internal high speed Error Comparator. The Comparator detects whether the output voltage achieves the required level. If output voltage is below the reference voltage, it will enable the oscillator signal to the control terminal of switching transistor, transferring the input into the output terminal to establish a stable voltage.

**Reference Voltage**

It provides a precise reference voltage as the reference to Error Comparator input terminal.

**Driver and Output Switch**

In order to emphasize the requirement for system application flexibility and high efficient conversion, Analog Integrations Corporation (AIC) introduces AIC1638 built-in type and AIC1639 external type models that user's can choose properly according the demands of application. The  $R_{DS(ON)}$  of N-MOSFET built in AIC1638 is 1 ~ 1.5Ω only which can reduce the conduction loss effectively due to the current flow through the MOSFET. Besides, AIC1639 provides an excellent output driving powered by means of a Push-Pull design. it gives the external transistor a full play.

**Selection of elements**

For the reason of obtaining the best performance of the system, it is necessary to consider the following peripheral elements:

**Inductor**

In order to reduce the loss caused by inductor DC resistance, it is wise to select an inductor with a small DC resistance (less than 1Ω is commanded), and value of inductance between 22μH and 1mH. If larger inductor is used, the peak current flowing through the inductor  $I_{peak}$ , will be reduced because the maximum energy stored in inductor is expressed as

$$\omega_L = \frac{1}{2} L \times I_{peak}^2 \dots\dots\dots(4)$$

Therefore, it is difficult to achieve voltage step up operation under a low input voltage condition. It also raises the minimum operating input voltage. However, the losses on inductor L and switching transistor Q will be reduced and the efficiency

will be improved because a small inductor peak current  $I_{PEAK}$ . On the other hand, using a small value inductance can reduce the minimum input voltage under a loading effectively. But it will aggravate the inductor efficiency for using a too small inductor. It is a trade-off problem depends on user's application.

Besides, switching peak current flowing through inductor many times, this is also the output current. The relationship between input and output efficiency can be expressed as:

$$\text{Input Power} \times \text{Efficiency} = \text{Output Power} \dots\dots\dots(5)$$

Than

$$(V_{IN} \times I_{IN}) \times \text{Efficiency} = (V_{OUT} \times I_{OUT}) \dots\dots\dots(6)$$

and

$$I_{IN(MAX)} = \frac{(V_{OUT(MA)}(I_{OUT(MAX)}))}{(\text{Efficiency})(V_{IN(MIN)})} \dots\dots(7)$$

Using the changing rate of current in inductor formula

$$V_L = L \frac{di}{dt} \dots\dots\dots(8)$$

to obtain the actual increasing rate of current

$$\Delta i = \frac{[(V_{IN(MIN)} - V_{SAT}) \times t_{ON}]}{L}, \dots\dots(9)$$

where  $V_{SAT}$  is the saturation voltage across transistor CE terminals.

Combining formula (6) with (9), we obtain

$$I_{PEAK} = I_{IN(MAX)} + 0.5(\Delta i) \dots\dots\dots(10)$$

For example, the required output is 3.3V, 100mA (max), and 80% efficiency. The input voltage of the cell is ranged from 0.9V to 1.8V, and  $L=33\mu H$ , transistor saturation voltage  $V_{SAT}$  is 0.3 V.

$$I_{PEAK} = \frac{3.3 \times 100 \times 10^{-3}}{0.8 \times 0.9} + \frac{1}{2} \frac{(0.9 - 0.3) \times 7.5 \times 10^{-6}}{33 \times 10^{-6}} = 0.526A \dots\dots\dots(11)$$

The inductor current at input terminal is much

higher than the output current. Therefore, it is wise to avoid a large current on the selection of inductor material. Since it may cause a faulty operation of magnetic saturation on inductor.

**Diode**

Select switching diode must meet the following requirements:

Low forward bias voltage  $V_F$  and .fast recovery speed,  $t_{SW}$  is better in application efficiency consideration.

Reverse voltage must  $> (V_{OUT} + V_F)$ , in which  $V_{OUT}=V_{DC} + \frac{1}{2} V_{RIPPLE}$

Maximum rated current  $> I_{PEAK}$ .

**Capacitor**

It is necessary to add an input capacitor  $C_{IN}$  at the input terminal. This improves the low efficiency due to the high impedance and instability at input terminal. Since the output capacitor is mainly used to reduce the ripple voltage, selecting a output capacitor with a high capacitance and low equivalent series resistance would be the best choice. The minimum capacitance at the output terminal should be larger than  $10\mu F$ . A tantalum electrolytic capacitor is recommended for its temperature characteristics and low leakage current.

For AC1639, output current can be increased effectively by applying an external pull transistor (see Figure 5). The value of  $R_B$  in the figure determines the transistors output capability. There is no significantly different performance for the value of  $R_B$  between  $50\Omega$  and  $500\Omega$ . However, it has been tested, result the best value of  $300\Omega$ . But under the situation that step-up ratio exceeding 4 or output achieving the limit,  $R_B$  can be reduced to  $100\Omega$  or even  $50\Omega$  to improve the output capability effectively. Value of  $R_B$  can be obtained by the following formula:

$$R_B = \frac{V_{OUT} - V_{BE} - 0.4}{I_B} \dots\dots\dots(12)$$

$$I_B = \frac{I_{PEAK}}{h_{FE}} \dots\dots\dots(13)$$

Using a small  $R_B$  will increase output current at price of lower efficiency. For the selection of transistor, one should choose a low saturation voltage ( $V_{CE-SAT}$ ). This can prevent low overall efficiency for high  $V_{CE-SAT}$  causing huge power loss on switching transistor. The speed-up capacitor paralleling with  $R_B$  can reduce the on/off switching loss to improve the efficiency.

**A quick check table of selecting external elements**

The relationship table among output current, efficiency, ripple voltage and choice of elements

**External Transistor**

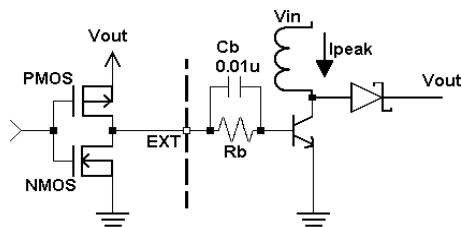

Figure 5. External switch peripheral circuit

|                                       |                      |                                    |   |
|---------------------------------------|----------------------|------------------------------------|---|
| For large Output Current?             | For High Efficiency? |                                    | For Small Ripple Voltage?               |
|                                       | Operation Efficiency | Stand by Efficiency                |   |
| <i>Decreasing L</i>                   | <i>Increasing L</i>  |                                    |   |
| Select small dc inductance resistance |                      |                                    |   |
|                                       |                      |                                    | Increase output capacitance, reduce ESR |
| Using External Tr. AIC1639            |                      | Using Built-in Tr. AIC1638         |   |
| Using AIC1639, select smaller $R_B$   |                      | Using AIC1639, select larger $R_B$ |   |

**Table 1. A quick table of selecting elements**

**Notes:**

- For the circuit implementation, the external elements should be as close to IC as possible.
- Make sure an effective grounding. If not so, increasing impedance relative to the ground would occur when switching current flows through ground pin. This can cause instability of IC.
- The capacitor value should be larger than  $10\mu\text{F}$  and behave good frequency characteristics. Additionally, a voltage spike usually occurs when the transistor is switching on/off. It is suggested to use a capacitor with high voltage endurance, e.g., three times as the output voltage.
- Schottky diode with low forward voltage VF is recommended
- In switching regulator application, ripple voltage and spike noise is closely related to the magnitudes of coil and capacitor. Be sure the proper magnitude is used.
- Make sure the power loss of switching transistor is within safe operating area (SOA).
- The performance of AIC1638/1639 is strongly correlated to the selection of peripheral elements. The magnitudes of voltage, current and power loss should not exceed the safe nominal value.

## Appendices

### AIC1638 Load regulation and Efficiency

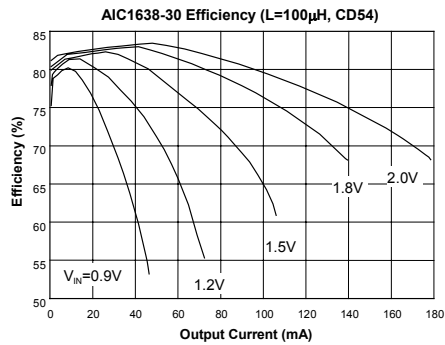
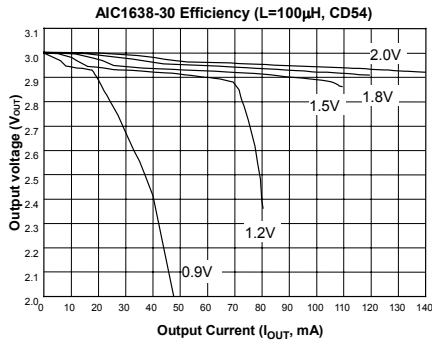

### AIC1639 Load regulation and Efficiency

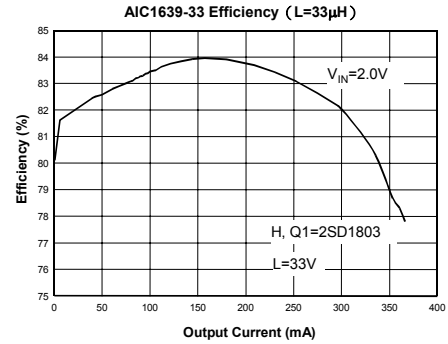
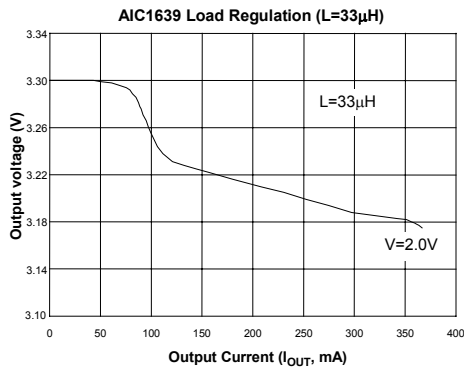

## Conclusion

AIC1638/1639 accomplishes the step-up voltage conversion with a minimal external element addition. Its exquisite package (SOT-89) taking a small space proves to be cost effective. Furthermore, an extraordinary output current driving power and high efficiency over a wide range of output current. The device can be widely used in many applications, particularly, those portable products based on cell as the power source, e.g., pager, walkman, electronic dictionary, MP3 player ... etc.