



High Efficiency Synchronous Step-Up DC/DC Converter

FEATURES

- High Efficiency 93% ($V_{IN}=2.4V$, $V_{OUT}=3.3V$, $I_{OUT}=200mA$).
- 20 μA Quiescent Supply Current.
- Power-Saving Shutdown Mode (0.1 μA typical).
- Internal Synchronous Rectifier (no external diode)
- Selectable Current Limit for Reduced Ripple (AIC1622).
- Low Noise , Anti-Ringing Feature (AIC1622)
- On-Chip Low Battery Detector.
- Low Battery Hysteresis

APPLICATIONS

- Palmtop & Notebook Computers.
- PDAs
- Wireless Phones
- Pocket Organizers.
- Cameras.
- 1 to 2-Cell Hand-Held Devices

DESCRIPTION

The AIC1620/AIC1621/AIC1622 are high efficiency step up DC-DC converter. The start-up voltage is as low as 0.8V and operate with an input voltage down to 0.7V. Consuming only 20 μA of quiescent current. These devices offer a built-in synchronous rectifier that reduces size and cost by eliminating the need for an external Schottky diode and improves overall efficiency by minimizing losses.

The switching frequency depends on the load and the input voltage can range up to 500KHz. The peak current of the internal switch is fixed at 0.8A (AIC1620), at 0.45A (AIC1621), or is selectable (AIC1622) for design flexibility. Ripple does not exceed the product of the switch current limit and the filter capacitor equivalent series resistance (ESR). The AIC1622 also features a circuit that eliminates noise due to inductor ringing.

TYPICAL APPLICATION CIRCUIT

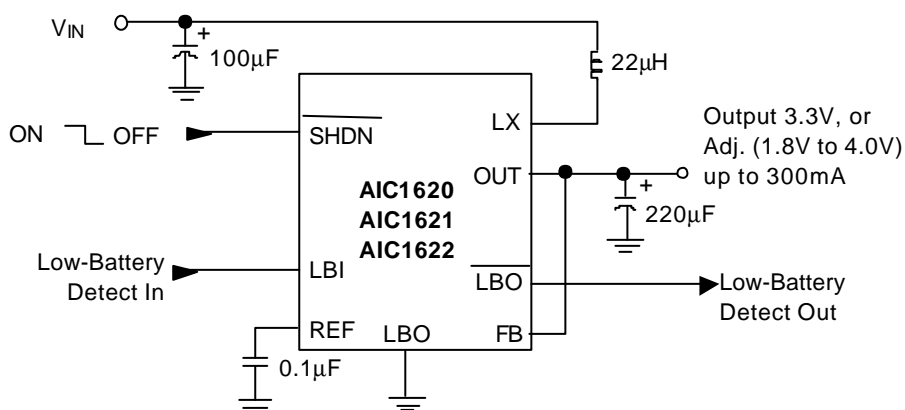

ORDERING INFORMATION

AIC1620CX XX
 AIC1621CX XX
 AIC1622CX XX

PACKING TYPE
 TR: TAPE & REEL

PACKAGING TYPE
 O: MSOP8 (for AIC1620/1)
 O: MSOP10 (for AIC1622)

Example: AIC1620COTR
 → In MSO8 Package & Taping &
 Reel Packing Type

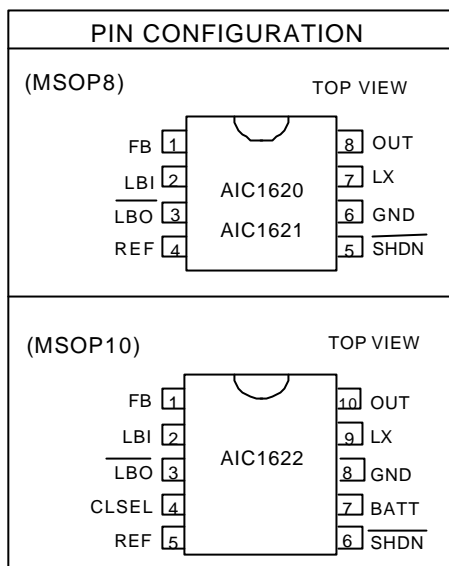

ABSOLUTE MAXIMUM RATINGS

Supply Voltage (OUT to GND)	8.0V
Switch Voltage (LX to GND)	$V_{OUT} + 0.3V$
Battery Voltage (Batt to GND)	6.0V
SHDN, LBO to GND	6.0V
LBI, REF, FB, CLSEL to GND	$V_{OUT} + 0.3V$
Switch Current (LX)	-1.5A to +1.5A
Output Current (OUT)	-1.5A to +1.5A
Operating Temperature Range	-40°C ~ +85°C
Storage Temperature Range	-65°C ~ 150°C

TEST CIRCUIT

Refer to Typical Application Circuit.

ELECTRICAL CHARACTERISTICS ($V_{BATT}=2.0V$, $V_{OUT}=3.3V$ (FB= V_{OUT}), $R_L=\mu$, $T_A=25^\circ C$, unless otherwise specified.)

PARAMETER	TEST CONDITIONS	MIN.	TYP.	MAX.	UNIT
Minimum Input Voltage			0.7		V
Operating Voltage		1.1		4.0	V
Start-Up Voltage	$R_L=3K\Omega$ (Note1)		0.8	1.1	V
Start-Up Voltage Tempco			-2		mV/°C
Output Voltage Range		1.8		4.0	
Output Voltage	FB = V_{OUT}	3.17	3.3	3.43	V
Steady State Output Current (Note 2)	FB=OUT ($V_{OUT}=3.3V$)	AIC1620 AIC1622 (CLSEL=OUT)	300	400	mA
		AIC1621 AIC1622 (CLSEL=GND)	150	220	
Reference Voltage	$I_{REF}=0$	1.199	1.23	1.261	V
Reference Voltage Tempco			0.024		mV/°C
Reference Load Regulation	$I_{REF}=0$ to 100 μA		10	30	mV
Reference Line Regulation	$V_{OUT}=1.8V$ to 4V		5	10	mV/V
FB , LBI Input Threshold		1.199	1.23	1.261	V
Internal switch On-Resistance	$I_{LX}=100mA$		0.3		Ω
LX Switch Current Limit	AIC1620,AIC1622(CLSEL = OUT)	0.6	0.8	1.0	A
	AIC1621,AIC1622(CLSEL = GND)	0.3	0.45	0.6	
LX Leakage Current	$V_{LX}=0V, 4V; V_{OUT}=4V$		0.05	1	μA
Operating Current into OUT (Note 3)	$V_{FB}=1.4V, V_{OUT}=3.3V$		20	35	μA
Shutdown Current into OUT	$\overline{SHDN}=GND$		0.1	1	μA
Efficiency	$V_{OUT}=3.3V, I_{LOAD}=200mA$		90		%
	$V_{OUT}=2V, I_{LOAD}=1mA$		85		
LX Switch On-Time	$V_{FB}=1V, V_{OUT}=3.3V$	2	4	7	μS
LX Switch Off-Time	$V_{FB}=1V, V_{OUT}=3.3V$	0.6	0.9	1.3	μS
FB Input Current	$V_{FB}=1.4V$		0.03	50	nA

ELECTRICAL CHARACTERISTICS (Continued)

PARAMETER	TEST CONDITIONS	MIN.	TYP.	MAX.	UNIT
LBI Input Current	$V_{LBI} = 1.4V$		1	50	nA
CLSEL Input Current	AIC1622, CLSEL = OUT		1.4	3	μA
\overline{SHDN} Input Current	$V_{\overline{SHDN}} = 0$ or V_{OUT}		0.07	50	nA
\overline{LBO} Low Output Voltage	$V_{LBI} = 0$, $I_{SINK} = 1mA$		0.2	0.4	μA
\overline{LBO} Off Leakage Current	$V_{\overline{LBO}} = 5.5V$, $V_{LBI} = 5.5V$		0.07	1	
LBI Hysteresis			50		mV
Damping Switch Resistance	AIC1622, $V_{BATT} = 2V$		50	100	Ω
\overline{SHDN} Input Voltage				$0.2V_{OUT}$	V
		$0.8V_{OUT}$			
CLSEL Input Voltage				$0.2V_{OUT}$	V
		$0.8V_{OUT}$			

Note 1: Start-up voltage operation is guaranteed without the addition of an external Schottky diode between the input and output.

Note 2: Steady-state output current indicates that the device maintains output voltage regulation under load.

Note 3: Device is bootstrapped (power to the IC comes from OUT). This correlates directly with the actual battery supply.

TYPICAL PERFORMANCE CHARACTERISTICS

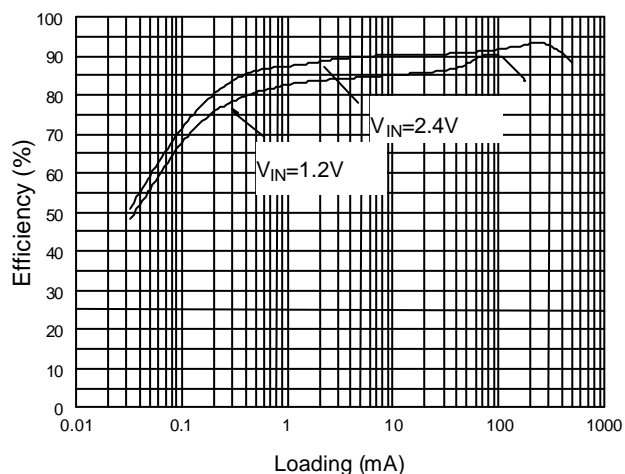

Fig. 1 $V_{OUT}=3.3V$ CLSEL=OUT (0.8A)

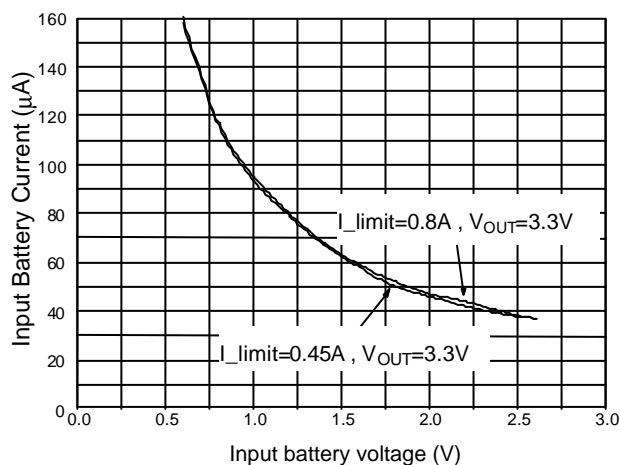

Fig. 2 No-Load Battery Current vs. Input Battery Voltage

TYPICAL PERFORMANCE CHARACTERISTICS (Continued)

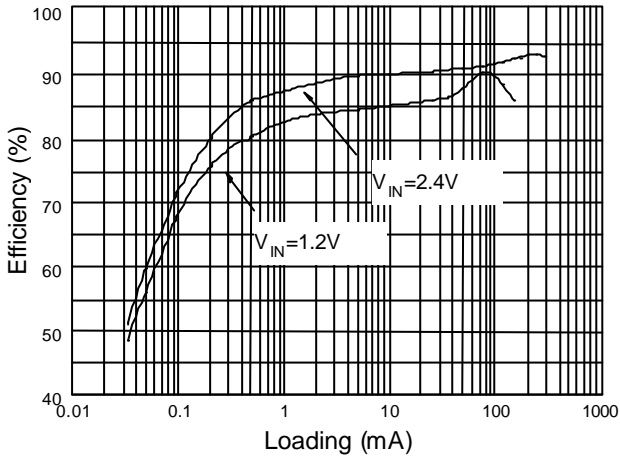

Fig. 3 $V_{OUT}=3.3V$ CLSEL=GND (0.45A)

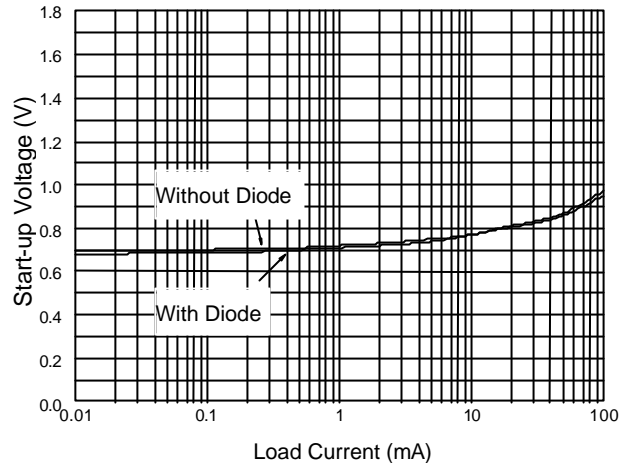

Fig. 4 Start-up Voltage vs. Load Current

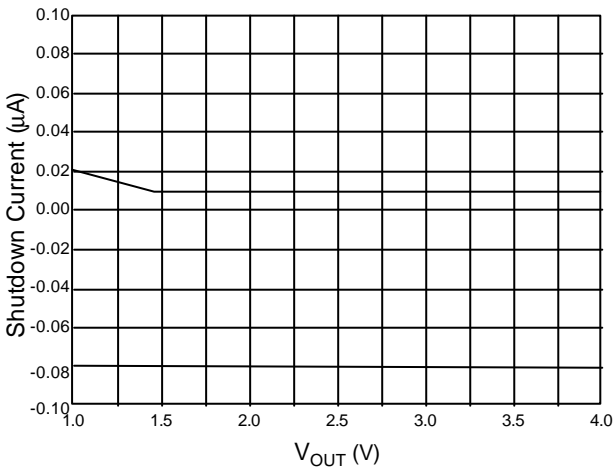

Fig. 5 Shutdown Current vs. V_{OUT}

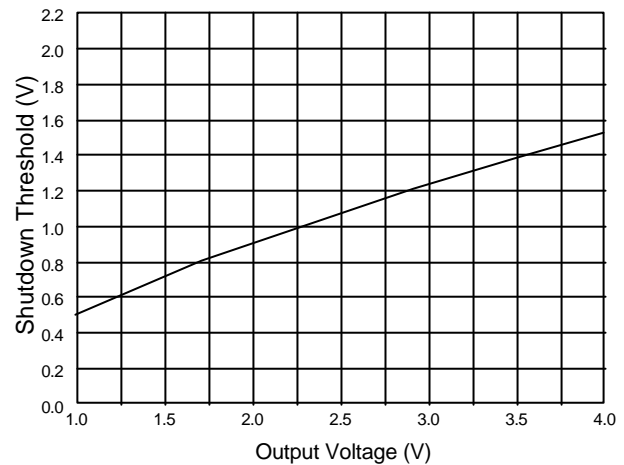

Fig. 6 Shutdown Threshold vs. Output Voltage

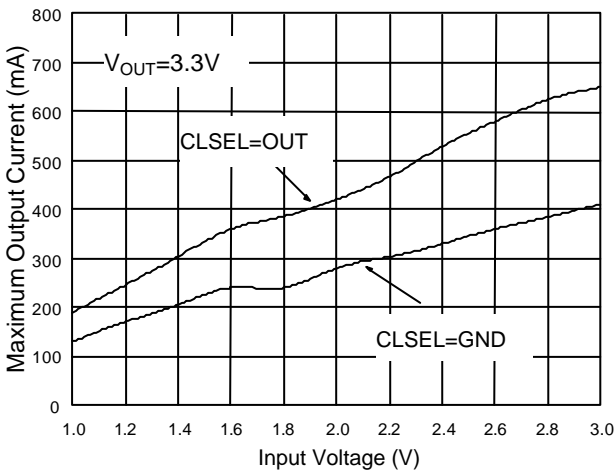

Fig. 7 Maximum Output Current vs. Input Voltage

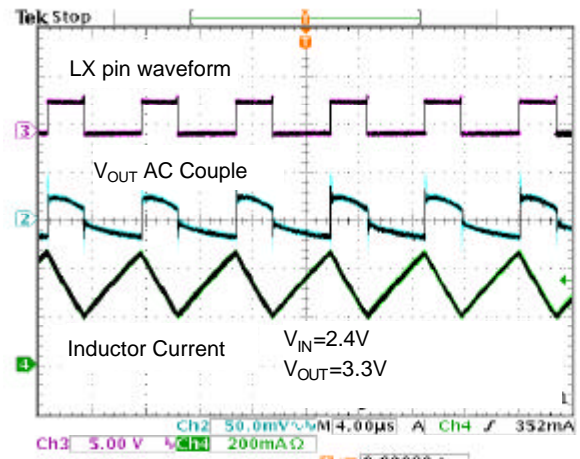

Fig. 8 Heavy Load Waveform

TYPICAL PERFORMANCE CHARACTERISTICS (Continued)

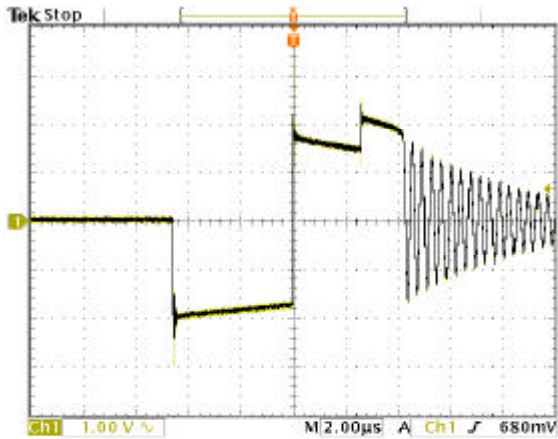

Fig. 9 Without Damping Ringing Function

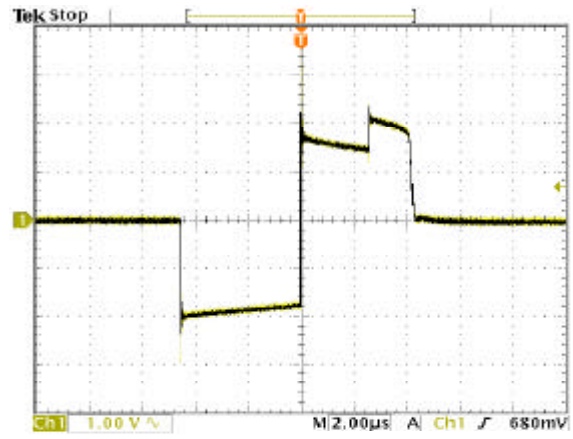

Fig. 10 With Damping Ringing Function

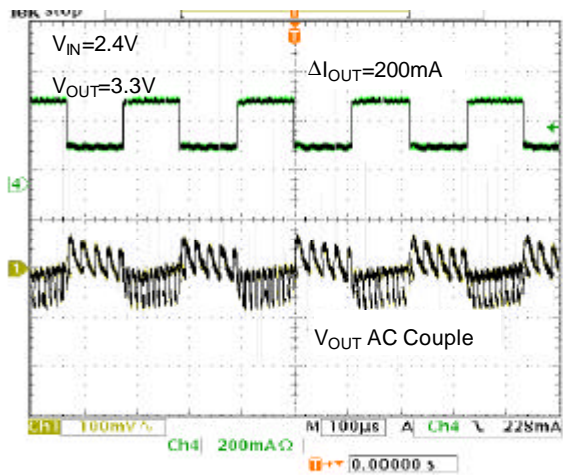
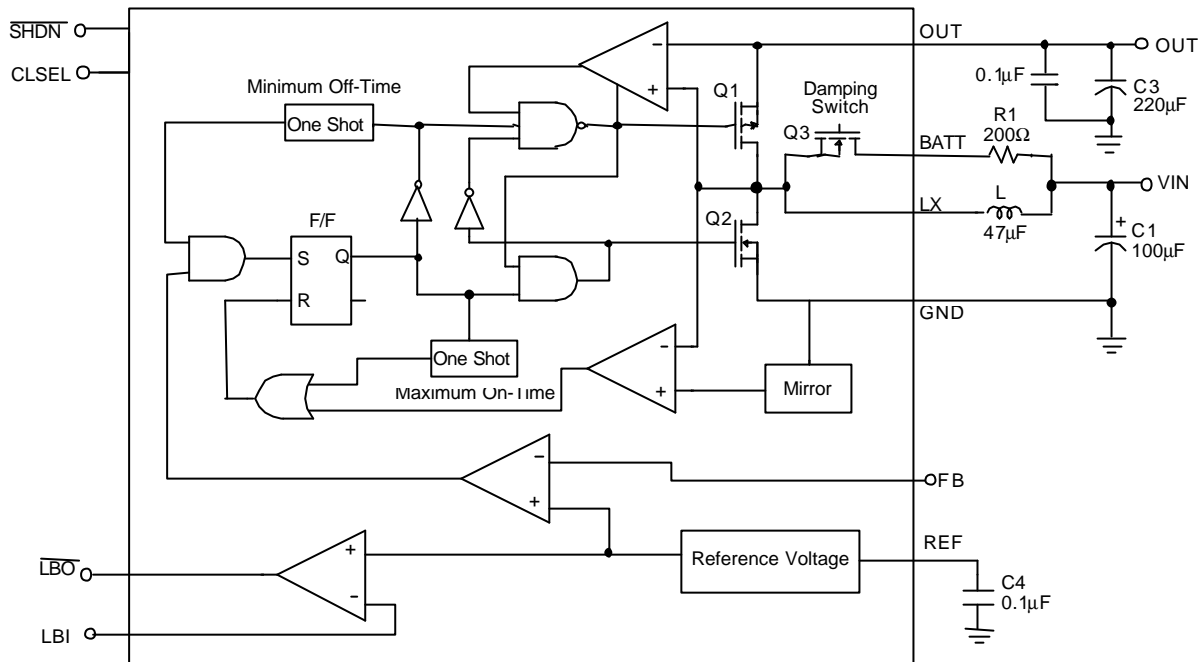

Fig. 11 Load Transient Response

■ BLOCK DIAGRAM



■ PIN DESCRIPTIONS

AIC1620/ AIC1621

- PIN 1: FB- Connect to OUT for +3.3V output. Use a resistor network to set the output voltage from +1.8V to +4.0V.
- PIN 2: LBI- Low-battery comparator input. Internally set to trip at +1.23V.
- PIN 3: $\overline{\text{LBO}}$ - Open-drain low battery comparator output. Output is low when V_{LBI} is <1.23V. $\overline{\text{LBO}}$ is high impedance during shutdown.

- PIN 4: REF- 1.23V reference voltage. Bypass with a 0.1 μ F capacitor.
- PIN 5: $\overline{\text{SHDN}}$ - Shutdown input. High=operating, low=shutdown.
- PIN 6: GND- Ground
- PIN 7: LX- N-channel and P-channel power MOSFET drain.
- PIN 8: OUT- Power output. OUT provides bootstrap power to the IC.

AIC1622

- PIN 1: FB- Connect to OUT for +3.3V output. Use a resistor network to set the output voltage from +1.8V to +4.0V.
- PIN 2: LBI- Low-Battery comparator input. Internally set to trip at +1.23V.
- PIN 3: $\overline{\text{LBO}}$ - Open-drain low battery comparator output. Output is low when VLBI is <1.23V. LBO is high impedance during shutdown.
- PIN 4: CLSEL- Current-limit selects input. CLSEL=OUT sets the current limit to 0.8A. CLSEL=GND sets the current limit to 0.45A.
- PIN 5: REF- 1.23V reference voltage. Bypass with a 0.1 μ F capacitor.
- PIN 6: $\overline{\text{SHDN}}$ - Shutdown input. High=operating, low=shutdown.
- PIN 7: BATT- Battery input and damping switch connection. If damping switch is unused, leave BATT unconnected.
- PIN 8: GND- Ground.
- PIN 9: LX- N-channel and P-channel power MOSFET drain.
- PIN 10: OUT- Power output. OUT provides bootstrap power to the IC.

APPLICATION INFORMATION

Overview

The AIC1620/AIC1621/AIC1622 series are high efficiency, step-up DC-DC converters, designed to feature a built-in synchronous rectifier, which reduces size and cost by eliminating the need for an external Schottky diode. The start-up voltage is as low as 0.9V and operate with an input voltage down to 0.7V. Quiescent supply current is only 20 μ A. In addition, the AIC1622 feature a circuit that eliminates inductor ring to reduce noise. The internal P-MOSFET on-resistance is typically 0.3 Ω to improve overall efficiency by minimizing AC losses. The current limit of the AIC1620 and AIC1621 are 0.8A and 0.45A respectively. The AIC1622 offers a selectable current limit(0.45A or 0.8A). The lower current limit allows the use of a physically smaller inductor in space-sensitive applications.

PFM Control Scheme

The key feature of the AIC1620 series is a unique minimum-off-time, current-limited, pulse-frequency-modulation (PFM) control scheme (see BLOCK DIAGRAM) with the ultra-low quiescent current. A constant-peak-current limit in the switching allows the inductor current to vary between this peak limit and some lesser value. The peak current of the internal N-MOSFET power switch can be fixed at 0.8A, 0.45A or is selectable. Besides, the ripple voltage dose not exceed the product of the peak current limit and the filter capacitor equivalent series resistance (ESR). The switch frequency depends on the loading condition and input voltage, and can range up to 500KHz. The switching frequency is governed by a pair of one-shots that set a minimum off-time (1 μ S) and a maximum on-time (4 μ S).

Synchronous Rectification

Using the internal synchronous rectifier eliminates the need for an external Schottky diode. Therefore, the cost and board space is reduced. During the cycle of off-time, the P-MOSFET turns on and shunts the N-MOSFET. Due to the low turn-on resistance of MOSFET, the synchronous rectifier significantly improves efficiency without the addition of an external component. Thus, the conversion efficiency can be as high as 93%.

Reference Voltage

The reference voltage (REF) is nominally 1.23V for excellent T.C. performance. In addition, REF pin can source up to 100 μ A to external circuit with good load regulation (<10mV). A bypass capacitor of 0.1 μ F is required for proper operation and good performance

Shutdown

The whole circuit is shutdown when $\overline{V_{SHDN}}$ is low. During shutdown mode, the current can flow from the battery to the output due to body diode of the P-MOSFET. V_{OUT} falls to approximately $V_{in}-0.6V$ and LX remains high impedance. The capacitance and load at OUT determine the rate at which V_{OUT} decays. Shutdown can be pulled as high as 6V. Regardless of the voltage at OUT.

Current Limit Select Pin

The AIC1622 series allows a selectable inductor current limit of either 0.45A or 0.8A. This allows flexibility in designing for higher current or smaller applications. CLSEL draws 1.4 μ A when connected to OUT.

BATT/Damping Switch

The AIC1622 is designed with an internal damping switch (Fig. 15) to reduce ringing at LX. The damping switch supply a path to quickly dissipate the energy stored in inductor and reduces the ringing at LX. Damping LX ringing dose not reduce V_{OUT} ripple, but dose reduce EMI. $R1=200\Omega$ works well for most application while reducing efficiency by only 1%. Larger R1 value provide less damping, but less impact on efficiency. In principle, lower value of R1 is needed to fully damp LX when the V_{OUT}/V_{IN} ratio is high.

Selecting the Output Voltage

V_{OUT} can be simply set to 3.3V by connecting the FB pin to OUT due to internal resistor divider (Fig. 16). In order to adjust the output voltage, a resistor divider is connected to V_{OUT} , FB, GND (Fig. 17). Use the following equation to calculate:

$$R5=R6 [(V_{OUT} / V_{REF}) -1]$$

Where $V_{REF}=1.23V$ and V_{OUT} may range from 1.8V to 4V.

Low-Battery Detection

The AIC1620 series contain an on-chip comparator with 50mV internal hysteresis (REF, REF+50mV) for low battery detection. If the voltage at LBI falls below the internal reference voltage. LBO (an open-drain output) sinks current to GND.

Component Selection

1. Inductor Selection

An inductor value of 22μH performs well in most applications. The AIC1620 series also work with inductors in the 10μH to 47μH range. An inductor with higher peak inductor current tends a higher output voltage ripple ($I_{PEAK} \times$ output filter capacitor ESR). The inductor's DC resistance significantly affects efficiency. We can calculate the maximum output current as follows:

$$I_{OUT(MAX)} = \frac{V_{IN}}{V_{OUT}} \left[I_{LIM} - t_{OFF} \left(\frac{V_{OUT} - V_{IN}}{2 \times L} \right) \right] \eta$$

where $I_{OUT(MAX)}$ =maximum output current in amps

V_{IN} =input voltage

L =inductor value in μH

η =efficiency (typically 0.9)

t_{OFF} =LX switch' off-time in μS

I_{LIM} =0.45A or 0.8A

2. Capacitor Selection

The output voltage ripple relates with the peak inductor current and the output capacitor ESR. Besides output ripple voltage, the output ripple current also needs to be concerned. The smaller the capacitor ESR is, the higher the ripple current will

be. A filter capacitor with low ESR is helpful to the efficiency and steady state output current of AIC1620 series. Therefore HERMEL capacitor LT series with 220μF/6.3V is recommended. A smaller capacitor (down to 10F with higher ESR) is acceptable for light loads or in applications that can tolerate higher output ripple.

3. PCB Layout and Grounding

Since AIC1622's switching frequency can range up to 500kHz, it makes AIC1622 become very sensitive. So careful printed circuit layout is important for minimizing ground bounce and noise. IC's OUT pin should be as clear as possible. And the GND pin should be placed close to the ground plane. Keep the IC's GND pin and the ground leads of the input and output filter capacitors less than 0.2in (5mm) apart. In addition, keep all connection to the FB and LX pins as short as possible. In particular, when using external feedback resistors, locate them as close to the FB as possible. To maximize output power and efficiency and minimize output ripple voltage, use a ground plane and solder the IC's GND directly to the ground plane. Following are the recommended layout diagrams.

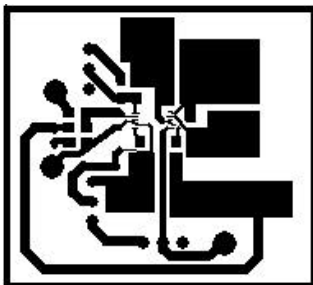

Figure 12. Top layer

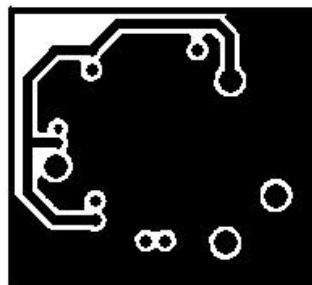

Figure 13. Bottom layer

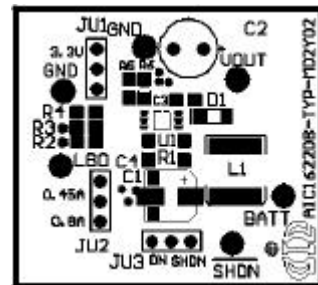

Figure 14. Placement

APPLICATION EXAMPLES

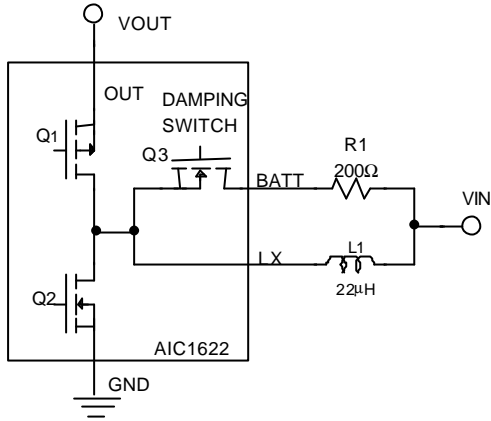

Fig. 15. Simplified Damping Switch Diagram

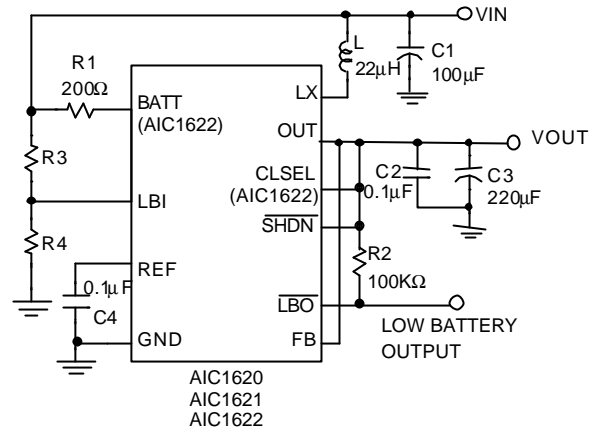

Fig. 16 V_{OUT} = 3.3V Application Circuit.

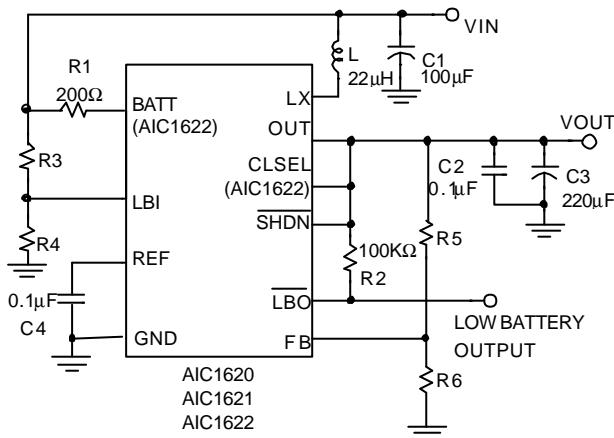
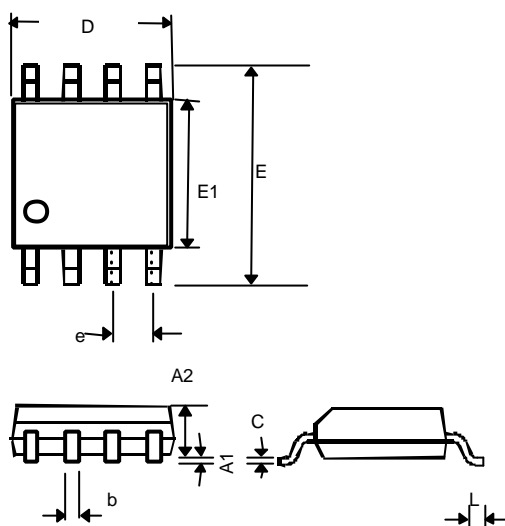

Fig. 17 An Adjustable Output Application Circuit

■ PHYSICAL DIMENSION

● 8 LEAD MSOP (unit: mm)



SYMBOL	MIN	MAX
A1	--	0.20
A2	0.76	0.97
b	0.28	0.38
C	0.13	0.23
D	2.90	3.10
E	4.80	5.00
E1	2.90	3.10
e	0.65	
L	0.40	0.66

● 10 LEAD MSOP (unit: mm)

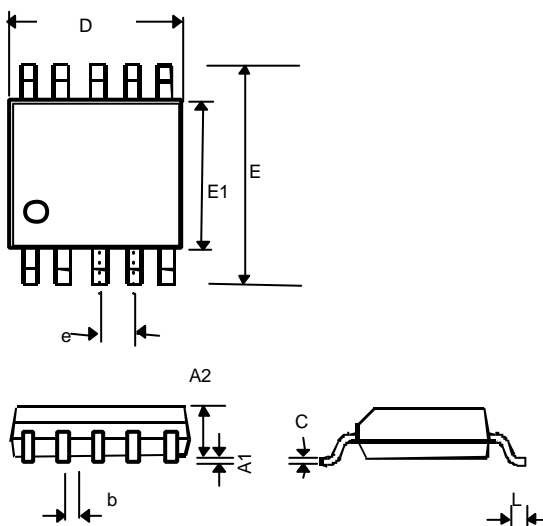

SYMBOL	MIN	MAX
A1	--	0.20
A2	0.76	0.97
b	0.15	0.30
C	0.13	0.23
D	2.90	3.10
E	4.80	5.00
E1	2.90	3.10
e	0.50	
L	0.40	0.66