

High-Efficiency, Step-Up DC/DC Controller

FEATURES

- 4V to 20V Input Voltage Operation.
- Adjustable Output Voltage.
- Low Quiescent Current at 100 μ A.
- Pulse-Skipping and Pulse-Frequency Modulation Maintain High Efficiency (max. 95%).
- 90KHz to 250KHz Oscillator Frequency.
- Power-Saving Shutdown Mode (8 μ A Typical).
- Push-Pull Driver Output.
- V_{REF} Pin Available.
- Current Limit Function Available.

APPLICATIONS

- Flash Memory Programming Power Supply.
- Positive LCD Contrast Bias for Notebook & Palmtop Computers.
- Step-Up DC/DC Converter Module.
- Telecom Power Supply.

DESCRIPTION

The AIC1628 is a high performance step-up DC/DC controller, designed to drive an external power switch to generate programmable positive voltages. In the particularly suitable LCD contrast bias and flash memory programming power supply applications, typical full-load efficiencies are 85% to 95%. 4V to 20V input operation range allows the AIC1628 to be powered directly by the battery pack in the most battery-operated applications for greater efficiency. Output voltage can be scaled to 40V or greater by two external resistors. A Pulse-Frequency Modulation scheme is employed to maintain high efficiency conversion under wide input voltage range. Quiescent current is about 100 μ A and can be reduced to 8 μ A in shutdown mode. Switching frequency being around 90KHz to 250KHz range, small size switching components are ideal for battery powered portable equipments, like notebook and palmtop computers.

TYPICAL APPLICATION CIRCUIT

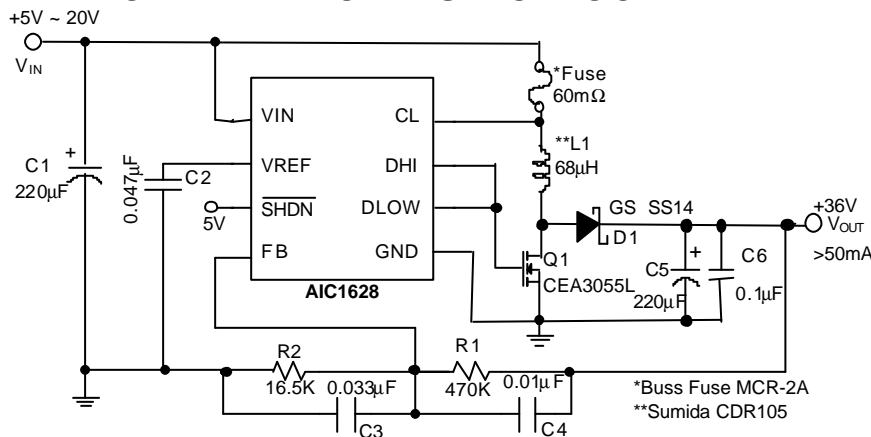

Color LCD Contrast Bias Supply

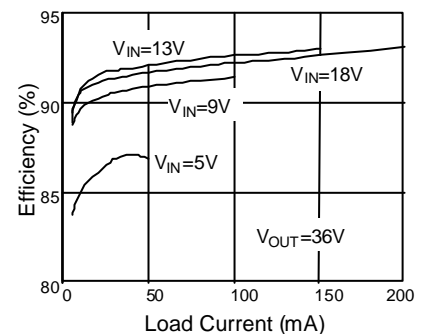

Efficiency vs. Output Current

ORDERING INFORMATION

AIC1628CXXX

PACKING TYPE
TR: TAPE & REEL
TB: TUBE

PACKAGE TYPE
N: PLASTIC DIP
S: SMALL OUTLINE

EX: AIC1628CSTR

→ in SO8 Package & Tape & Reel Packing Type
(CN is not available in TR packing type.)

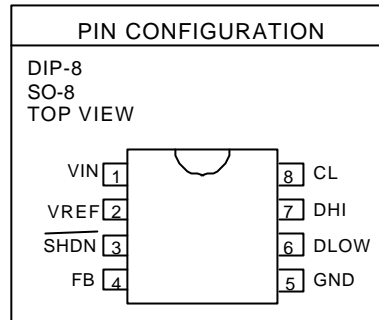

ABSOLUTE MAXIMUM RATINGS

VIN Supply Voltage (V_{IN} Pin) 20V

$\overline{\text{SHDN}}$ Pin Voltage..... 15V

Operating Temperature Range 0°C~70°C

Storage Temperature Range -65°C~ 150°C

TEST CIRCUIT

Refer to Typical Application Circuit

ELECTRICAL CHARACTERISTICS ($V_{IN}=13V$, $T_A=25^\circ C$, unless otherwise specified.)

PARAMETERS	TEST CONDITIONS	MIN.	TYP.	MAX.	UNIT
Input Voltage		4		20	V
Quiescent Current	$V_{FB} = 1.5V$		100	200	μA
Shutdown Mode Current	$V_{\overline{\text{SHDN}}} = 0V$		8	20	μA
VREF Voltage	$I_{\text{SOURCE}} = 250\mu A$	1.16	1.22	1.28	V
VREF Source Current		250			μA
DLOW "ON Resistance"			15		Ω
DHI "ON Resistance"			10		Ω
CL Threshold	$V_{IN} - V_{CL}$	50	70	90	mV
Shutdown Threshold		0.8	1.5	2.4	V
Shutdown Input Leakage Current	$V_{\overline{\text{SHDN}}} < 15V$			1	μA

TYPICAL PERFORMANCE CHARACTERISTICS

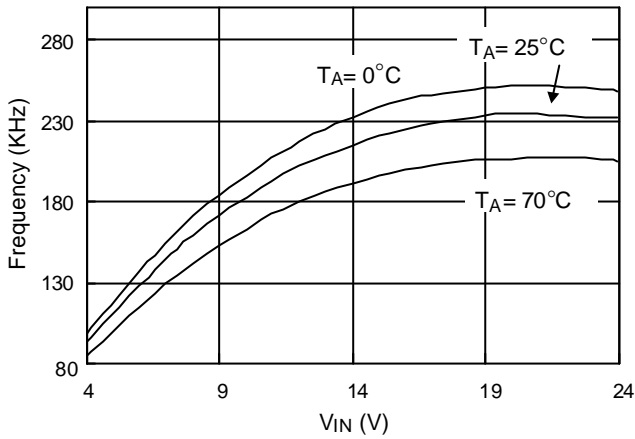

Fig. 1 Frequency vs. V_{IN} Voltage

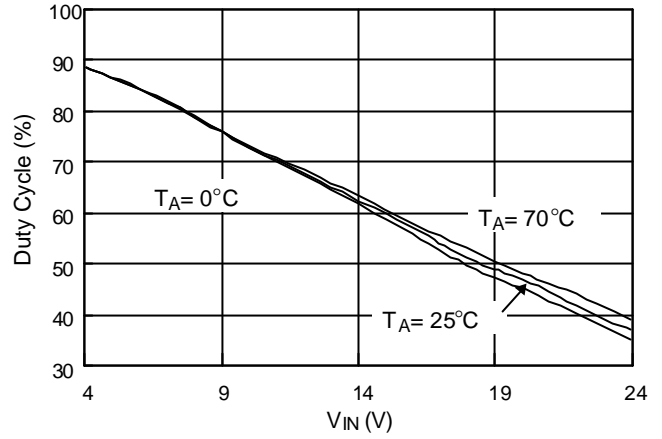

Fig. 2 Duty Cycle vs. V_{IN} Voltage

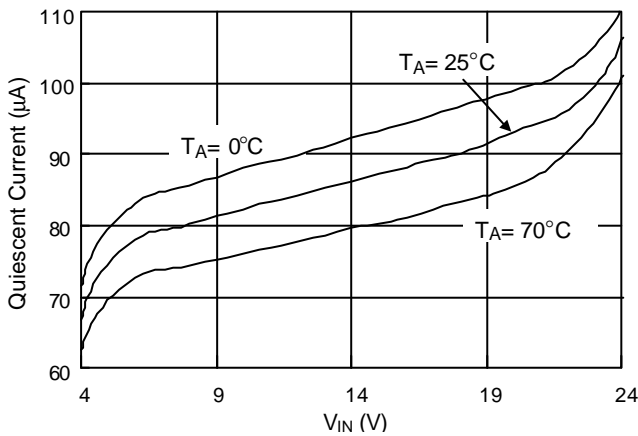

Fig. 3 Quiescent Current vs. V_{IN} Voltage

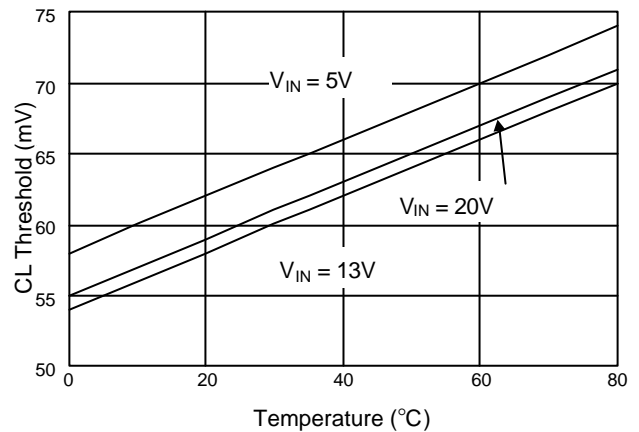

Fig. 4 Current Limit Threshold vs. Temperature

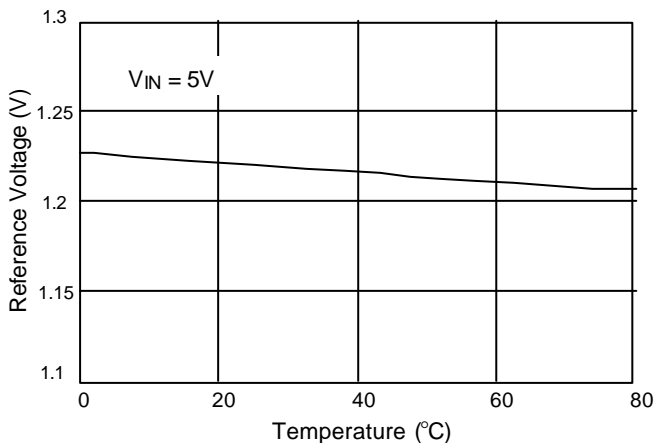
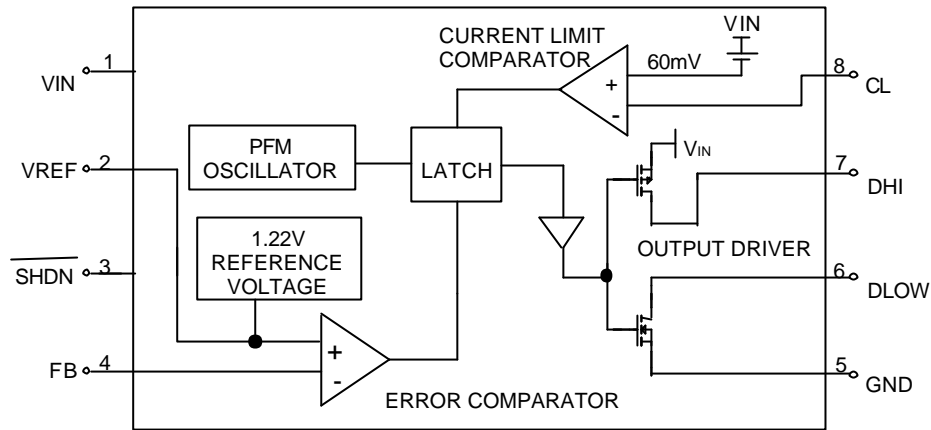

Fig. 5 Reference Voltage vs. Temperature

■ BLOCK DIAGRAM



■ PIN DESCRIPTIONS

PIN 1: VIN - Input supply voltage is from 4V to 20V.

PIN 2: VREF - Reference output is 1.22V. Bypass with a 0.047 μ F capacitor to GND. Sourcing capability is guaranteed to be greater than 250 μ A.

PIN 3: $\overline{\text{SHDN}}$ - Logical input to shutdown the chip.
 >1.5V = normal operation,
 GND = Shutdown,
 Can not be floating or forced greater than 15V. In shutdown mode DLOW and DHI pins are at low level.

PIN 4: FB - Feedback signal input to sense VREF. Connecting a resistor R1 to V_{OUT} and a resistor R2 to GND yields the output voltage:

$$V_{\text{OUT}} = (R1+R2)/R2 \times V_{\text{REF}}$$

(Refer to typical application circuit)

PIN 5: GND - Power ground.

PIN 6: DLOW - Connected to gate of the external N-channel MOSFET or base of the NPN bipolar transistor.

PIN 7: DHI - Driver sourcing output. Connected to DLOW when using an external N-channel MOSFET. When using an external NPN bipolar transistor, connect a base resistor RB from this pin to DLOW. RB value depends on VIN, inductor and NPN current gain.

PIN 8: CL - Current-limit input. Threshold voltage is 60mV from VIN. This pin clamps the switch peak current to prevent over-current damage to the external switch, under abnormal conditions.

APPLICATION EXAMPLES

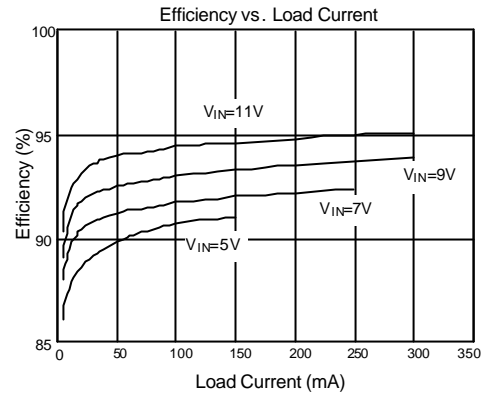
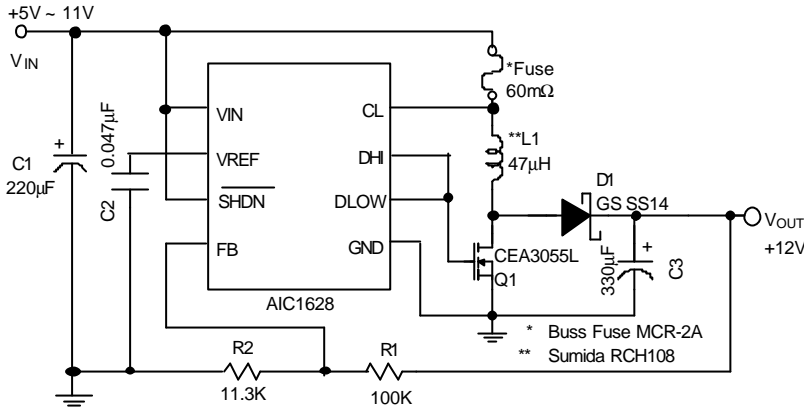

Fig. 6 Flash memory programming supply

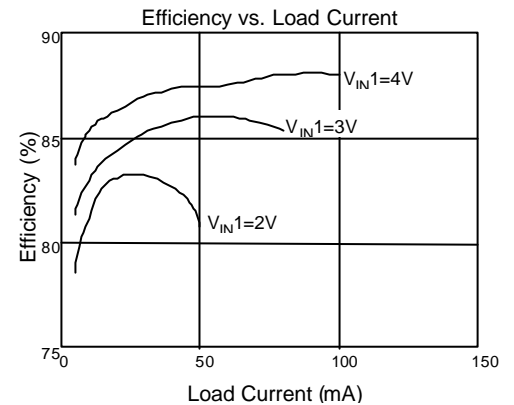
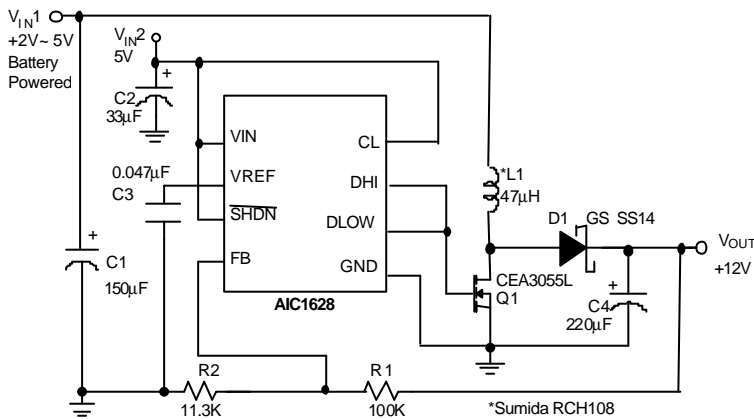

Fig. 7 2-cells to +12V Flash memory programmer

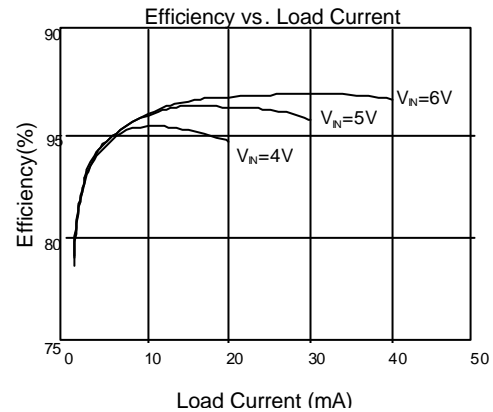
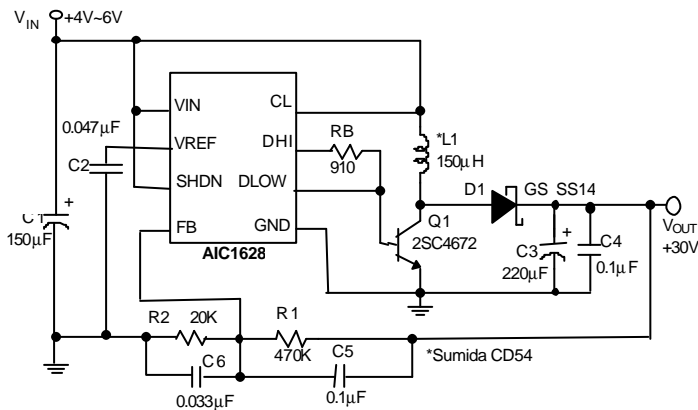

Fig. 8 4-cells to +30V power supply

APPLICATION EXAMPLES (Continued)

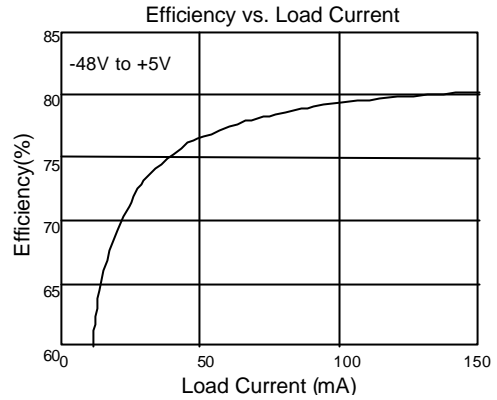
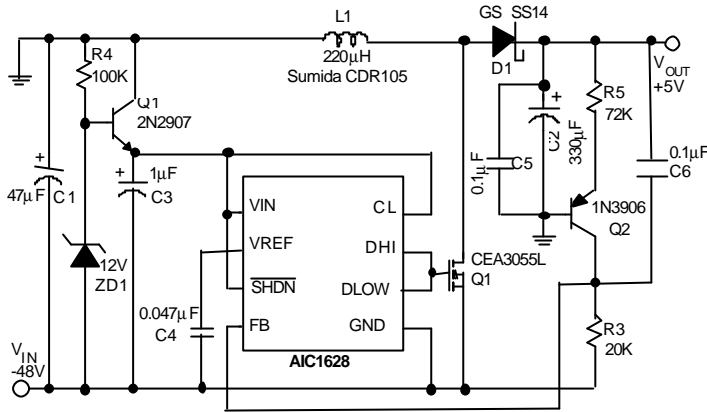

Fig. 9 Telecom +5V supply

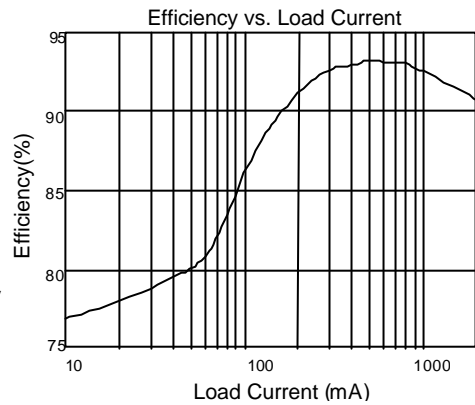
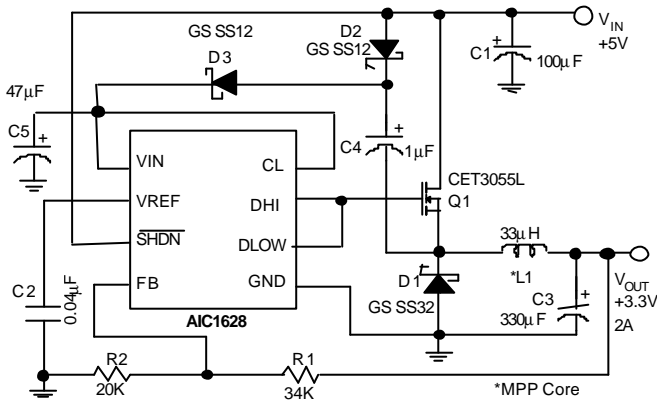
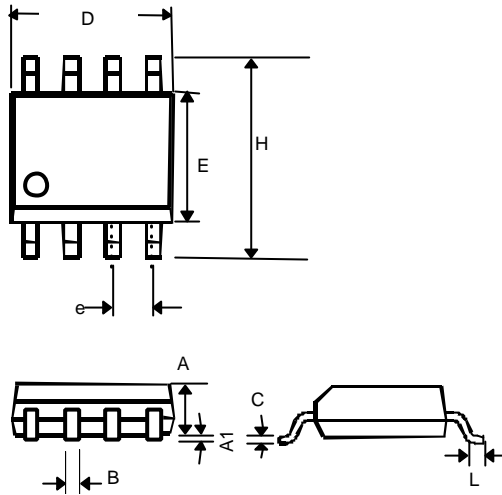

Fig. 10 5V to 3.3V step-down converter

PHYSICAL DIMENSIONS

8 LEAD PLASTIC SO (unit: mm)



SYMBOL	MIN	MAX
A	1.35	1.75
A1	0.10	0.25
B	0.33	0.51
C	0.19	0.25
D	4.80	5.00
E	3.80	4.00
e	1.27(TYP)	
H	5.80	6.20
L	0.40	1.27

8 LEAD PLASTIC DIP (unit: mm)

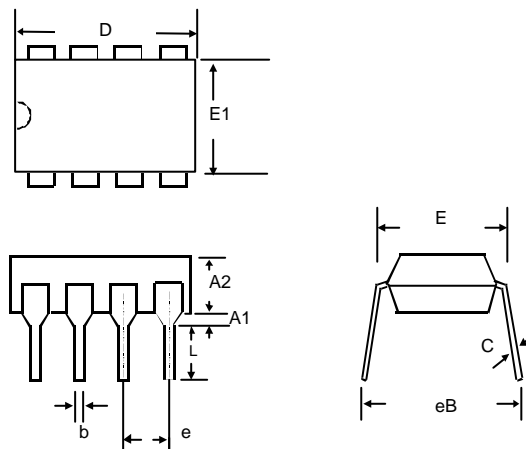

SYMBOL	MIN	MAX
A1	0.381	—
A2	2.92	4.96
b	0.35	0.56
C	0.20	0.36
D	9.01	10.16
E	7.62	8.26
E1	6.09	7.12
e	2.54 (TYP)	
eB	—	10.92
L	2.92	3.81