

---

## 8-Channel Darlington Drivers

### ■ FEATURES

- Improved Replacement for ULN2803.
- Fast Turn-on and Turn-off.
- TTL/CMOS Compatible.

### ■ APPLICATIONS

- Stepping Motor Driver.
- Relay Driver.
- LED Driver.
- Solenoid Driver.

### ■ DESCRIPTION

Manufactured with the standard bipolar process, the AIC2803 is a high-voltage, high-current 8-channel Darlington array, with each of the output transistors capable of sinking peak load current of 500mA and capable of withstanding at least 50V in the OFF state.

The AIC2803 has a 2.7K $\Omega$  series base resistor to each Darlington pair and thus allows operation directly with TTL or CMOS logic circuitry operating at a supply voltage of 5V. Outputs of the drivers can be paralleled for higher load current capability. These make the AIC2803 ideally suited for numerous interfaces between low-level logic circuitry and high-power peripheral loads, particularly those beyond the capabilities of standard logic buffers. Typical loads include relays, solenoids, stepping motors, heaters, multiplexed LED, and incandescent displays.

The AIC2803 features open collector outputs and integral diodes for inductive load transient suppression.

**■ TYPICAL APPLICATION CIRCUIT**

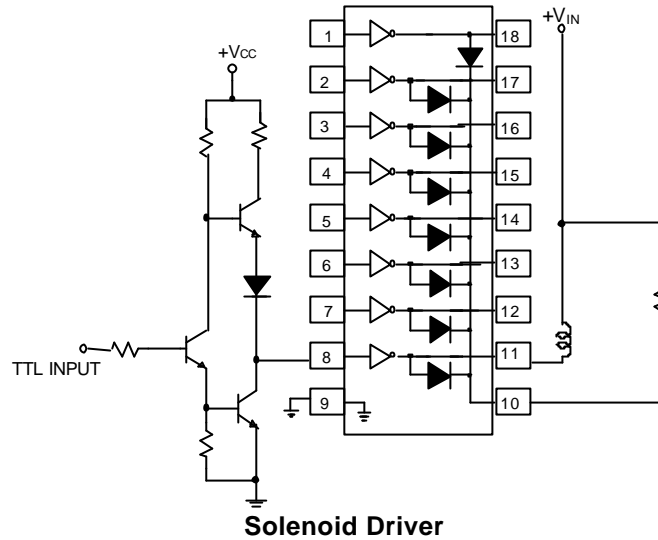

**■ ORDERING INFORMATION**

AIC2803CXXX

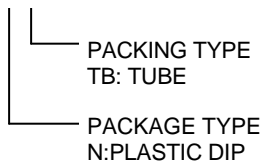

Example: AIC2803CNTB  
→ in DIP-18 Package & Tube  
Packing Type

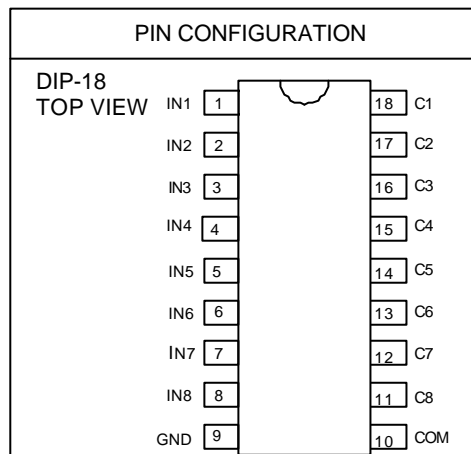

**■ ABSOLUTE MAXIMUM RATINGS (T<sub>A</sub>=25°C)**

Output Voltage .....	50V
Input Voltage .....	30V
Continuous Collector Current .....	500mA
Continuous Base Current .....	25mA
Power Dissipation, (One Darlington Pair) .....	1.0W
(Total Package) .....	2.25W
Operating Ambient Temperature Range .....	-20°C~ 85°C
Storage Temperature Range .....	-65°C~ 150°C

**■ ELECTRICAL CHARACTERISTICS** ( $T_A=25^{\circ}\text{C}$ , unless otherwise specified.)

PARAMETERS	TEST CONDITIONS	SYMBOL	MIN.	TYP.	MAX.	UNIT
Output Leakage Current	$V_{CE}=50\text{V}, T_A=25^{\circ}\text{C}$ $V_{CE}=50\text{V}, T_A=70^{\circ}\text{C}$ , Fig. 1	$I_{CEX}$			30 100	$\mu\text{A}$
Collector-Emitter Saturation Voltage	$I_C=100\text{mA}, I_B=250\mu\text{A}$ $I_C=200\text{mA}, I_B=350\mu\text{A}$ $I_C=350\text{mA}, I_B=500\mu\text{A}$ , Fig. 2	$V_{CE(SAT)}$		0.8 0.9 1.0	1.1 1.3 1.5	V
Input Current	$V_{IN}=3.85\text{V}$ , Fig. 3 $I_C=500\mu\text{A}, T_A=70^{\circ}\text{C}$ , Fig. 4	$I_{IN(ON)}$ $I_{IN(OFF)}$		0.93 50	1.35 65	mA $\mu\text{A}$
Input voltage	$V_{CE}=2.0\text{V}, I_C=200\text{mA}$ $V_{CE}=2.0\text{V}, I_C=250\text{mA}$ $V_{CE}=2.0\text{V}, I_C=300\text{mA}$ , Fig. 5	$V_{IN(ON)}$			2.3 2.4 2.5	V
Input Capacitance		$C_{IN}$		15	25	pF
Clamp Diode Leakage Current	$V_R=50\text{V}, T_A=25^{\circ}\text{C}$ $V_R=50\text{V}, T_A=70^{\circ}\text{C}$ , Fig. 6	$I_R$			30 100	$\mu\text{A}$
Clamp Diode Forward Voltage	$I_F=350\text{mA}$ Fig. 7	$V_F$		1.4	1.8	V
Turn-On Delay	$0.5 V_{IN}$ to $0.5 V_{OUT}$ , Fig. 8	$T_{ON}$		0.1	0.5	$\mu\text{S}$
Turn-off Delay	$0.5 V_{IN}$ to $0.5 V_{OUT}$ , Fig. 8	$T_{OFF}$		0.2	0.8	$\mu\text{S}$

■ TEST CIRCUITS

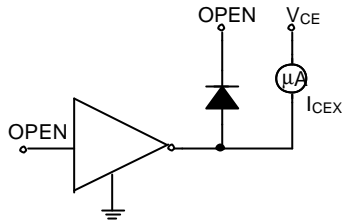

Fig. 1

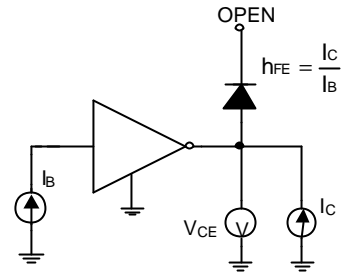

Fig. 2

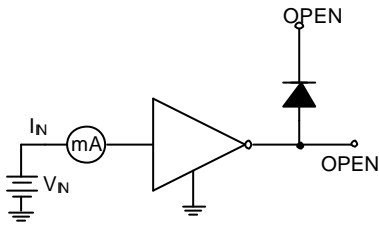

Fig. 3

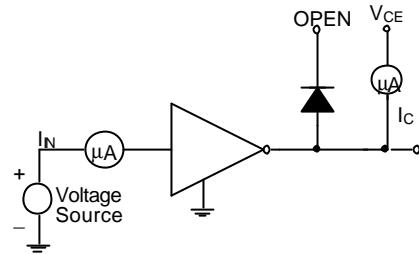

Fig. 4

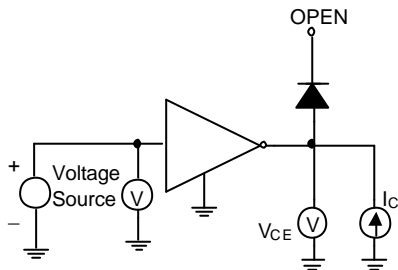

Fig. 5

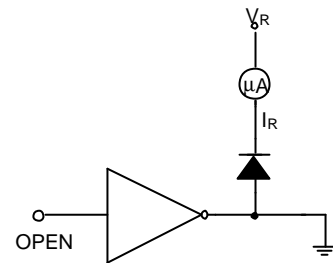

Fig. 6

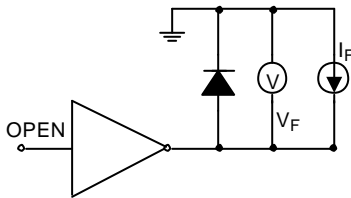

Fig. 7

■ TEST CIRCUITS (Continued)

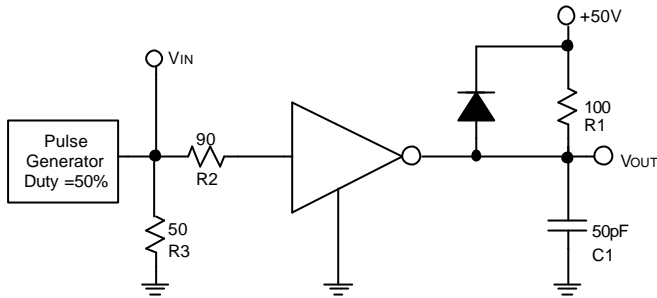

Fig. 8

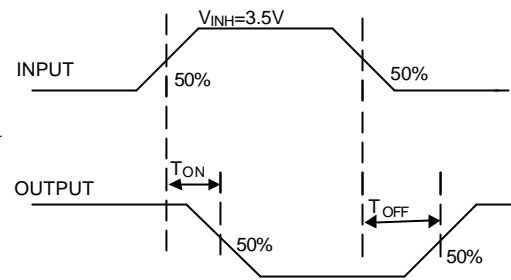
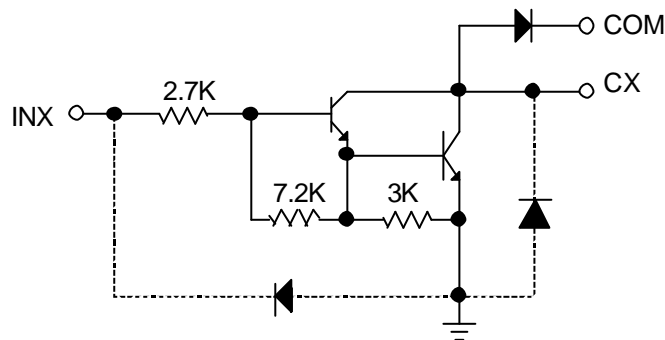

Fig. 9 Test Circuit of Fig. 8

■ PIN DESCRIPTIONS

- PIN 1~8: IN1~IN8 - Control signal input pin.
- PIN 9: GND - Power ground.
- PIN 10: COM - The output pin (Cathode) of freewheeling diode.
- PIN 11~18: C1~C8 - Each of the pins may individually sink load current from some controlled circuits. The sunk current should be under 500mA in a continuous mode.

■ DRIVER CIRCUIT



**SWITCHING DELAY**

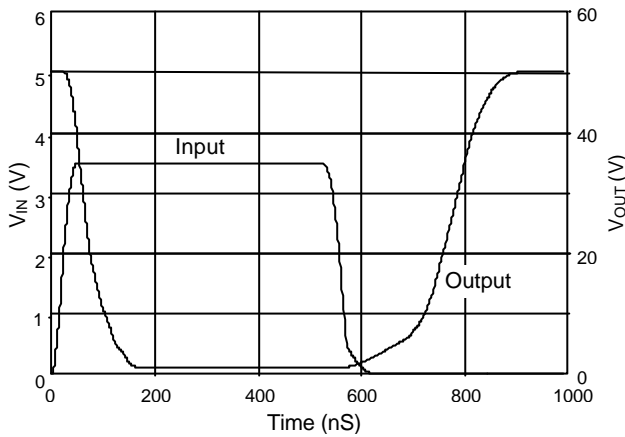

Fig. 10 Switching Delay

**ALLOWABLE AVERAGE POWER DISSIPATION**

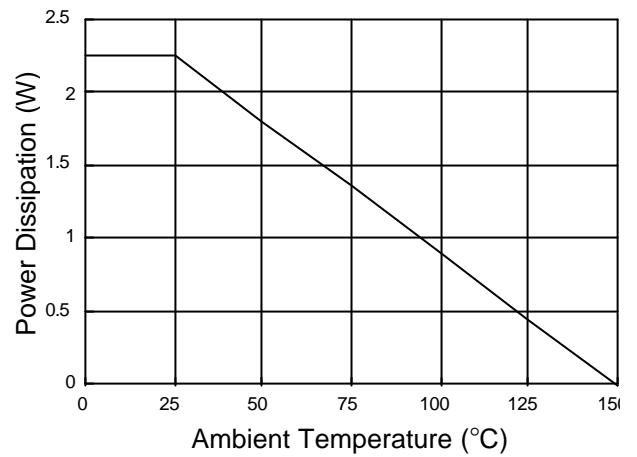
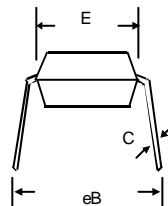
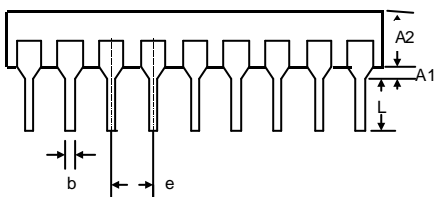
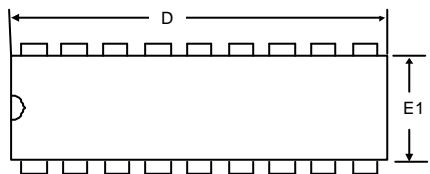

Fig. 11 Power Dissipation vs. Ambient Temperature

**PHYSICAL DIMENSIONS**

- 18 LEAD PLASTIC DIP (unit: mm)



SYMBOL	MIN	MAX
A1	0.381	—
A2	2.92	4.96
b	0.35	0.56
C	0.20	0.36
D	22.35	23.37
E	7.62	8.26
E1	6.09	7.12
e	2.54 (TYP)	
eB	—	10.92
L	2.92	3.81